



AS/NZS
4777.2:2015
COMPLIANT



enaSOLAR

GT Series Solar Inverter Manual v2.5

About EnaSolar

EnaSolar designs, manufactures and distributes efficient, cost effective, sustainable and upgradeable solar inverters to the global market.

EnaSolar and the EnaSolar 'e' are both registered trademarks. Copyright © 2012 EnaSolar. No part of this document may be reproduced in any form or disclosed to third parties without the express written consent of EnaSolar Limited, 66 Treffers Road, Christchurch 8042, New Zealand.

EnaSolar reserves the right to revise this document and to periodically make changes to the content without obligation to give prior notification of such changes, unless required to do so by prior arrangement.

Exclusion for Documentation

Unless specifically agreed to in writing, EnaSolar makes no warranty as to the accuracy, sufficiency, or suitability of any technical or other information provided in its manuals or other documentation.

EnaSolar assumes no responsibility or liability for losses, damages, costs or expenses, whether special, direct, indirect, consequential or incidental, which might arise out of the use of such information. The use of any such information will be entirely at the user's risk.

Manual Version

DN120166D EnaSolar GT Series Solar Inverter Manual - MAN-ESENG-v2.5

Applicable for Products

5KWGT-AUNZ	5KWGT-AU4.6	4KWGT-AUNZ	3.8KWGT-AUNZ
3KWGT-AUNZ	2KWGT-AUNZ	1.5KWGT-AUNZ	

Installation Details

The following table must be filled in by the installer:

Installer's Company:				
Installer's Name:				
Installer's Tel/Email:				
Inverter Model:				
Inverter Serial Number:				
Installation Date:				
Panel Manufacturer:				
Panel Model:				
Panel Configuration:	No. of strings:		No. of panels per string:	

Contents

1. ABOUT THIS MANUAL	3
Purpose and Audience	3
Safety Instructions	3
Important Notice to the Installer	3
Warranty Information	3
2. INTRODUCTION	4
About the Inverter	4
3. INSTALLATION	4
Mechanical Specifications	4
Installation Options	4
Location Requirements	6
Installing the Wall Mount	7
4. WIRING	7
Wall Mount	7
Earthing of Solar Arrays	9
Inverter Module	11
DRM Capability	12
Multiple Inverter Operation	12
Testing the Voltages	13
5. CONFIGURATION	13
Configuration Overview: New Connection or Re-Connection	13
Configuration Details	14
Inverter Configuration Software	15
Configuration through the Inverter Web Page	16
Ethernet Connection	17
Ad-hoc Wi-Fi Connection	17
Default Ad-hoc Wi-Fi Settings:	18
Infrastructure Wi-Fi Connection	18
Infrastructure Wi-Fi Setup through a USB Connection	19
Infrastructure Wi-Fi Setup through an Ad-hoc Wi-Fi Connection	19
6. COMMISSIONING THE SYSTEM	20
Fitting the Display Module	20
Using the Inverter	20
Stopping the Inverter	21
Maintenance	21
Warranty Information	21
7. ADVANCED USAGE	21
Advanced Settings	22
Advanced Settings - Network	22
Advanced Settings - Grid Connect	22
Advanced Settings - Other	22
8. TROUBLESHOOTING	23
Installer Serviceable Components	23
General Troubleshooting	24
9. UNDERSTANDING THE PART NUMBER	26
10. GLOSSARY	26
11. TECHNICAL SPECIFICATIONS	27

1. ABOUT THIS MANUAL

Purpose and Audience

The purpose of this manual is to explain the procedures for installing and troubleshooting the EnaSolar GT Series Solar Inverter.

The inverter must be installed by a suitably qualified solar technician. Please read this manual thoroughly before installing the inverter.

Under no circumstances should the home owner carry out any electrical work on the inverter. Such work must be carried out by the original installer or a qualified electrician.

Safety Instructions



WARNING – If the inverter is used in a manner not specified by the manufacturer, the protection provided by the equipment may be impaired.



WARNING - Risk of Electric Shock.

Unless you are a qualified electrician, you must not open the inverter or attempt any type of repair or modification to the wiring. Never attempt to remove, repair or modify the inverter until the AC and DC power have been disconnected.



WARNING - Risk of Electric Shock.

Do not open the inverter electronics module. There are no user serviceable parts inside the module. There may still be a high residual voltage within the inverter itself even if you have switched off the power source.



WARNING – Danger of Burn Injuries.

When the device is in use it can become quite hot (up to 70°C in normal operation, depending on the ambient temperature). Do not touch the inverter while it is being operated or you may get burnt.



WARNING – Fire Hazard.

Do not cover or obstruct the inverter, because it could overheat and become a fire hazard.



Please consult the wiring section on Page 8.

Make sure the wiring is kept in good condition and is the correct size and type for its purpose.

When installing the inverter, ensure you follow the recommended clearances and location instructions. Do not install the inverter in a location that does not have ventilation. This could lead to overheating, damage to the unit, significantly reduced product life or reduced power output.

Important Notice to the Installer

This manual must remain in the possession of the customer. Once the installation has been completed the relevant data must be filled in at the start of this manual. This data may be used for the customer's reference and to aid in any technical assistance.

Warranty Information

Warranty information is available on our website: <https://www.enasolar.net/products/>

EnaSolar accepts no responsibility for any changes that are made to a home network system, e.g. router.

2. INTRODUCTION

About the Inverter

The EnaSolar GT Series Solar Inverter is designed to convert DC solar power to AC (mains) power, which can be used to power appliances in a home or business.

Inverter Features:

- Built-in Wi-Fi as standard for PV system monitoring & reporting.
Optional Ethernet version available.
- Integrated lockable AC and DC isolating switches.
- Wide operating voltage range starting at 120V, allowing you to install with a minimal panel array.
- 5 year warranty included as standard, upgradeable to 10 years.
- Front mounted heat sink allows more airflow, easy care and cleaning.
- A more efficient design means longer product life and less call outs.

3. INSTALLATION

Mechanical Specifications

1.5/2.0kW Models	3.0/3.8kW Models	4.0/5.0kW Models
330mm x 550mm x 145mm		401mm x 600mm x 168mm
14kg	15kg	20kg

Installation Options

1.5-3.8kW models have one PV input and the 4.0/5.0kW models have two independent MPPT PV inputs. Each input can be connected to a single solar string or to two solar strings in parallel, provided the strings connected to the input are identical. Inputs to the 4.0/5.0kW models should not be connected together.

Multiple inverter combinations:

As per AS/NZS 4777.2:2015, valid inverter combinations include any combination of inverters, provided that:

- 1) Multiple inverters must be installed so that no more than 21.7A maximum rated output to the grid is fitted per phase.
- 2) Multiple inverters must be connected via multiple inverter shutdown ports as per section 4 (page 13) of this manual.

The inverter can be connected to a home network using either Wi-Fi or Ethernet depending on the model.

Check that the solar panel configuration is suitable for the inverter. Check site voltage, size of incoming mains, loop impedance. When fitting two strings of panels to the same input, ensure that the panels on each string are identical in model and quantity.

A computer with the latest version of the Inverter Configuration Software installed is required. Windows XP or later is required.

A USB to USB mini-B cable is required to connect the computer to the inverter or, if using the external USB connector, a USB to USB-B (male).

Obtain the required network settings from the customer. For a Wi-Fi connection, these will include the Wi-Fi network name, security mode (open, WEP or WPA are supported) and password - see the [Configuration](#) section for further information.

Included with this manual is a Certificate of Conformity and the following inverter components:

INCLUDED INVERTER COMPONENTS



Wall Mount (1x)



Display Module (1x)



Inverter Module (1x)



Antenna (1x)
(Wi-Fi version only)

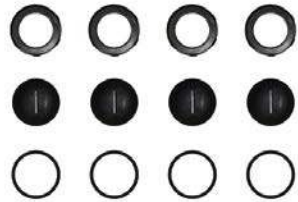

**Conduit Bung
Assembly (4x)**



**Mounting Hardware
Assembly (6x)**

Carefully disconnect the three connectors from the Display Module PCB by pulling on the connector, not on the cable. (Earth Tab, Communications Cable, Wi-Fi Coaxial Connector).

Set the Display Module aside. Disconnect the Inverter Module plugs by squeezing the side release tabs and carefully pulling out. Lift off the Inverter Module and then set aside.



Disconnecting Display Module Connectors

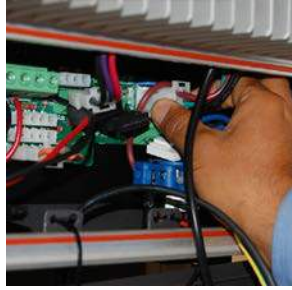

Disconnecting Inverter Module Plugs



Removing the Inverter Module

Location Requirements

The warranty may be compromised if the inverter is not installed in accordance with the installation guidelines. Our standard warranty terms can be found at <https://www.enasolar.net/products>

The inverter can be installed indoors or outdoors. It should be installed in a location somewhere with a free flow of air, where the ambient temperature is between -25°C and $+50^{\circ}\text{C}$ ($+40^{\circ}\text{C}$ for 3.8kW model). It should be installed in a location that is out of direct sunlight during peak power times when the sun is at its hottest. The minimum requirements for airflow around the heat sink are a major factor contributing to efficient cooling of the inverter and as a result the inverter should never be installed where these minimum space requirements are not met.

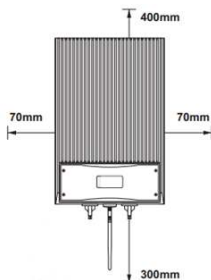

Inverter Mounting Clearances

The inverter must be mounted at an angle no greater than 45 degrees forwards or backwards with the AC and DC isolating switches at the bottom on a wall or other flat surface. Allow at least 400mm clearance from the top, 300mm from the bottom and 70mm on each side of the inverter.

Do not mount inverters above each other or another source of hot air. Do not install the inverter anywhere that it is likely to accumulate debris such as tree leaves or large amounts of dust. Do not mount the inverter in a cupboard or an enclosed space with no air flow as this may cause the inverter to overheat and potentially cause damage.

The Wall Mount must be attached to a flat surface such as plaster board, wood siding, masonry or a pole assembly. Make sure the mounting surface can support the weight of the inverter before you begin. If you are installing on plaster board, use supporting material such as plywood or secure the fasteners to supporting wall studs. The Wall Mount must not be installed directly on galvanised steel. Eliminate the chance of dissimilar metal corrosion by using the supplied mounting hardware.

To use the inverter's Wi-Fi connection, the customer's wireless router must provide a minimum of 30% signal strength at the inverter location. Any metal structures near or around the inverter can affect the Wi-Fi signal.

Installing the Wall Mount

The Wall Mount comes with six pre-drilled 8mm holes for attaching it to the wall, as well as eight conduit holes for electrical wires.

Mark and drill at least four mounting holes, fit the Wall Mount with the supplied Mounting Hardware, ensuring it is attached securely.

Inspect the installation for any potential water leaks. Seal using an appropriate silicone sealant if required.

Note: If the inverter is incorrectly installed, this will invalidate the warranty. Please see our warranty terms and conditions on our website.

4. WIRING

Wall Mount



WARNING - Risk of Electric Shock.

Before you begin ensure that the:

Inverter's AC and DC switches are locked in the 'OFF' position.

Incoming DC wires are disconnected at the solar array.

Inverter's circuit breaker on the distribution board is in the 'OFF' position.



WARNING - Fire Hazard.

Using undersized wiring can result in a fire hazard.

All wiring must be carried out in accordance with local regulations by suitably qualified technicians. Wire size is critical as undersized wiring can lead to significant power losses and a reduction in system efficiency. Use outdoor rated wiring if the inverter is installed outside.



PLEASE READ – Wiring Instructions.

		1.5kW	2.0kW	3.0kW	3.8kW	4.0kW	5.0kW
AC	AC Wire Size:	2.5mm ² – 16mm ²		4mm ² – 16mm ²			
	Temp Rating:	75°C					
	Torque:	All sizes 1.2 – 1.5Nm					
	Recommended AC Circuit Breaker Sizes:*	16A		20A		32A	
Earth	Earth Wire Size:	2.5 – 25mm ² copper, or 4 -25mm ² aluminum, or as required by the electrical wiring regulations					
	Temp Rating:	75°C					
	Earth Terminal Torque:	4.5 – 8 Nm					
DC	DC Wire Size:**	4mm ² – 16mm ²					
	Temp Rating:	75°C					
	Torque:	1.2 – 1.5 Nm					

* The AC breaker in the customer's distribution board must be rated for bidirectional power flow. AC wire size must be coordinated with the AC breaker used in the customer's distribution board.

** DC wire size must be coordinated with the solar panels' maximum short circuit current. The maximum size for the DC wire is 16mm² (6 AWG), solid or stranded copper wire only. DC wire insulation must be rated for the solar array open circuit voltage. A minimum of 600V insulation is recommended.

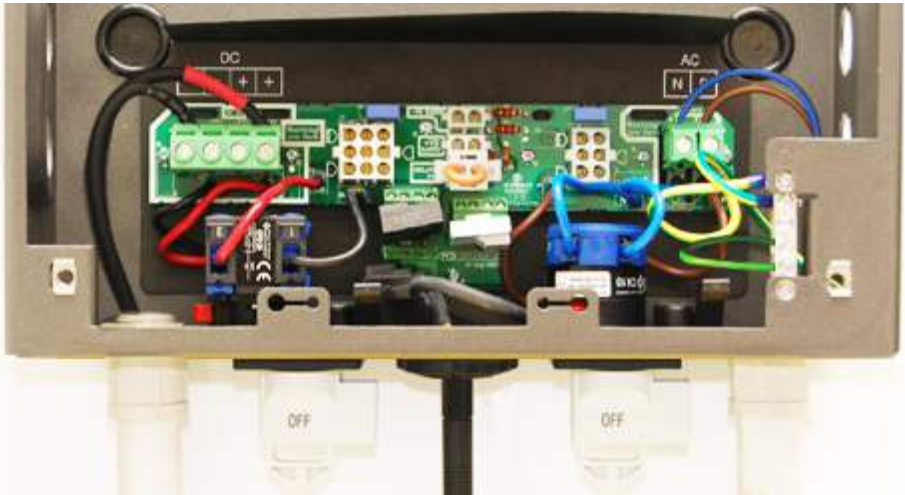

Wall Mount Sample Wiring - 1.5 to 3.8kW Models.

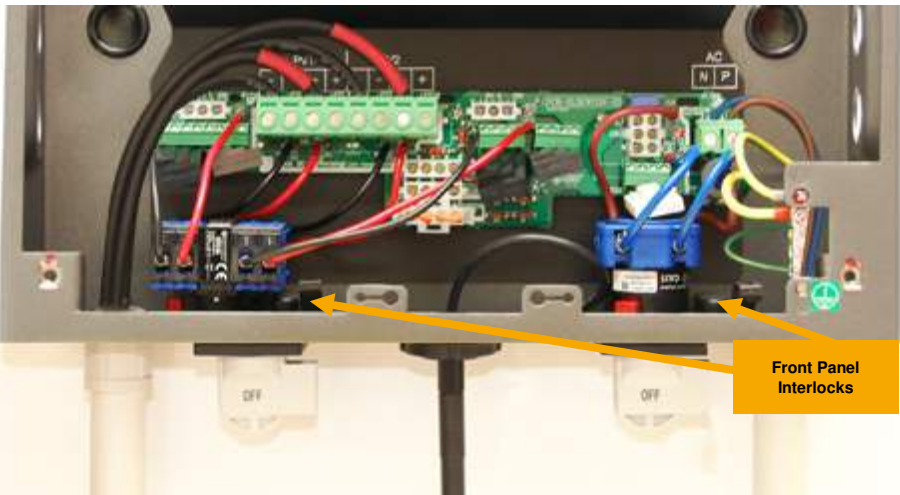

Wall Mount Sample Wiring - 4.0/5.0kW Models.

EnaSolar inverters are fitted with mechanically interlocked AC and DC switches which prevent access to the wiring behind the front panel while the switches are in the "on" position.

The Wall Mount has eight conduit holes. Choose appropriate conduit holes depending on the installation location. Mark DC wires to differentiate between positive and negative and between panel strings if multiple strings are being used (e.g. PV1+, PV1-, PV2+, PV2-). Route the AC wires, DC wires and Ethernet cable (if fitted) through separate conduits to the Wall Mount. Ensure all unused conduit entry points are fitted with the supplied Conduit Bungs.

1.5-3.8kW models have one MPPT PV input and the 4.0/5.0kW models have two independent MPPT PV inputs. Each MPPT input can be connected to a single solar string or to two solar strings in parallel, provided the strings connected to the input are identical. Inputs to the 4.0/5.0kW models should not be connected together.

If multiple inverters are installed it is recommended that inverters are wired to different phases.

Strip 9mm of insulation from the AC and DC wires.

The DC terminals marked '-PV' and '+PV' allow wiring of two strings of panels in parallel per MPPT input. Connect the DC wires to the terminals and tighten to 1.2-1.5 Nm (10.6-13.3 Lb-In). The earth wire from the solar array frame should be connected to the earthing bar.

Screw in the antenna (Wi-Fi version) to the bottom of the Wall Mount.

If you are not installing the Inverter Module at this stage an additional Service Cover can be fitted to maintain fixed wiring protection. The Service Cover is available from your EnaSolar distributor.

Earthing of Solar Arrays



WARNING - Risk of Electric Shock.

Before you begin ensure that the inverter's AC and DC switches are locked in the 'OFF' position.

Note: This section refers to earthing the positive or negative of the solar array. The panel frames should always be connected to earth.

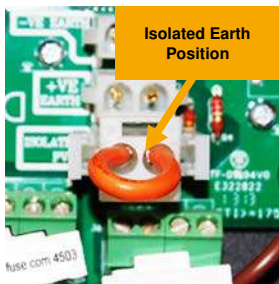

Earth Positions – 1.5 – 3.8kW inverter

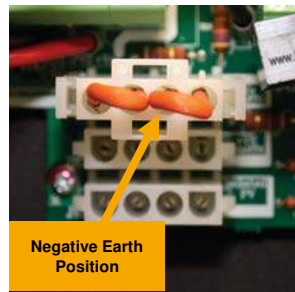
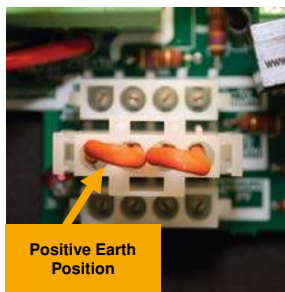
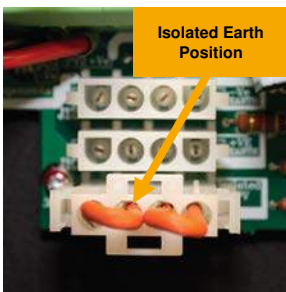

Earth Positions – 4, 4.6, 5.0kW inverter

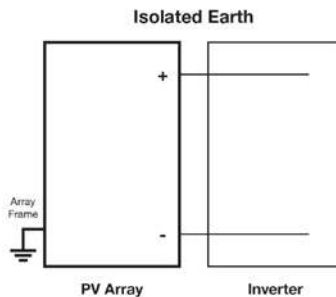
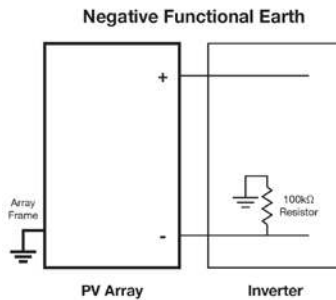
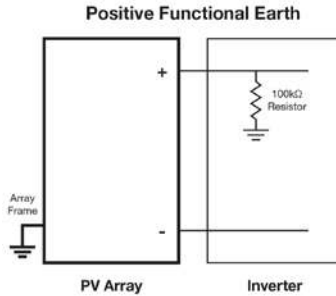

Earthing Block Diagram

Some solar panels require earthing of either positive or negative DC, check with the panel manufacturer to see if this is necessary. The EnaSolar GT Series Solar Inverter provides isolated, negative or positive earthing options. Inverters use an internal 100kΩ resistance to provide functional positive or negative earthing of the panels.

Isolated Earth System (Default): The positive and negative from the solar array are isolated from earth. On startup, the inverter verifies there is >50kΩ impedance between each DC input and earth. If the inverter detects lower impedance, it will display 'PV Earth Fault' and the red LED will light. Depending on the inverter configuration, the inverter may continue generating in this state – see the [Configuration Details](#) section.

Any earth fault identified by the inverter must be resolved. If concurrent earth faults occur, an electrically unsafe situation exists and could result in fire. See 'PV Earth Fault' in the [Troubleshooting](#) section.

Negative or Positive Earth System: Some panels (particularly thin film) require the negative or positive wire from the solar array to be connected to earth. The electrical connection is made through a 100kΩ resistance. (Functional earth).

The functional earthing configuration is changed by moving a jumper between connectors labelled +VE Earth, -VE Earth and Isolated PV.

When configuring the inverter using the Inverter Configuration Software, be sure to select the appropriate option based on the position of the earthing jumper and whether the Earth Fuse is fitted (older hardware versions only).

Inverter Module



WARNING - Risk of Electric Shock.

Before you begin ensure that the inverter's AC and DC switches are locked in the 'OFF' position.

Before installing the Inverter Module ensure:

- Every ingress point of water and dust is sealed.
- No loose items, wire strands or debris are left inside the Wall Mount.
- The Mounting Hardware is not over-torqued.

Hang the Inverter Module on top of the Wall Mount, ensuring no wires are caught between the inverter module and the wall mount.

Connect the AC and DC plugs to the Wall Mount. AC plugs have black, brown and green wires, DC plugs have black, red and purple wires.

Connect the Earth Tab and inverter's Communication Cable to the Display Module. For the Wi-Fi version, connect the Wi-Fi Coaxial Connector. For the Ethernet version, connect the Ethernet cable. Leave the Display Module open so that you can continue with configuration.



Connecting the Inverter Module



**Display Module (Wi-Fi)
with Connections**



Display Module (Ethernet)

Demand Response Mode (DRM) Capability

All EnaSolar inverters have been fitted with hardware to provide DRM0 capability.

DRM0 functionality disconnects the inverter from the AC mains, or reconnects it, based on a signal from a lines company device called a Demand Response Enabling Device (DRED). Please refer to AS/NZS 4777.2:2015 sec 6.2.

To connect DRM capability, follow these steps:

- a) With the front panel open, route a suitable cable (ie twin core signal cable, minimum) from the DRED, into the inverter wall mount.

Ensure that you maintain any necessary IP rating and wiring rules practice. It may be necessary to provide double insulation on the cable: it is recommended to do this as standard.

- b) Terminate the cable pair into the connector block (labelled 'DRM Port') (polarity is not important)
- c) Using the solar installer software, locate the Demand Response Mode (DRM) setting under 'Setup'. Set the DRM0 feature to 'enabled'.
- d) Correct operation can be tested by connecting the two wires at the DRED end. This should cause the inverter to disconnect from the AC mains (activate the relay).



Multiple Inverter Operation

AS/NZS 4777.2:2015 sec 8.3 and 8.4 stipulates that a system that incorporates multiple inverters must provide a functionality to disconnect and reconnect **all** inverters to the AC mains if **any one** inverter has done so.

To configure this capability, follow these steps:

- a) You will need one twisted pair from a CAT 5/6 cable.
- b) With the front panel open, route a twisted pair cable (one pair of CAT 5/6) between each inverter wall mount.

Ensure that you maintain any necessary IP rating and wiring rules practice. It may be necessary to provide double insulation on the cable and we recommend doing this as standard.

Terminate the cable pair into the terminal block (labelled 'REMOTE SHUTDOWN') on each inverter. Note, it is **IMPORTANT** that polarity is consistent and must be maintained across all connectors.

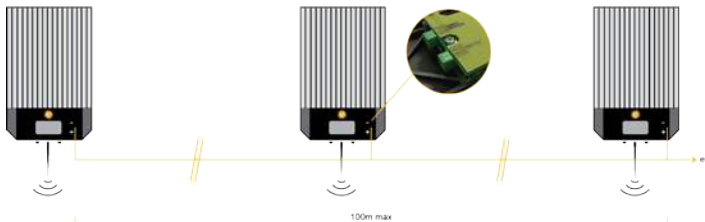

- c) Test and confirm connection and re-connection during the commissioning of the system.

Testing the Voltages



WARNING - Risk of Electric Shock.

Before you begin ensure that the inverter's AC and DC switches are locked in the 'OFF' position.

Re-connect the solar array or arrays and measure the voltage across the DC input terminals in the Wall Mount, when the array is exposed to daylight. To prevent damage to the Inverter this voltage must be greater than 150V DC and less than 500V DC for the 1.5-3.8kW models or 600V DC for all other models. Turn on the DC switch and measure the voltage at the DC terminals. If the DC voltage drops below 10V this indicates reversed polarity wiring from the solar array which must be resolved.

Switch on the inverter's circuit breaker at the customer's AC distribution board and measure the voltage at the AC terminals in the Wall Mount. The nominal voltage should be approximately 230/240V AC.

5. CONFIGURATION

Configuration Overview: New Connection or Re-Connection

This process and instruction can be used for new customers for first time installations or where a re-connection is required, such as when replacing a router. **WARNING:** This is deemed electrical work and must only be carried out by a qualified professional.

A connection between a computer and the inverter is required to configure customer specific settings. There are four different connection methods as detailed below. For most installations, a USB connection is recommended for initial configuration. After configuration, the customer will generally use Ethernet or Wi-Fi to access the Inverter Web Page to view information or to further customise their inverter.

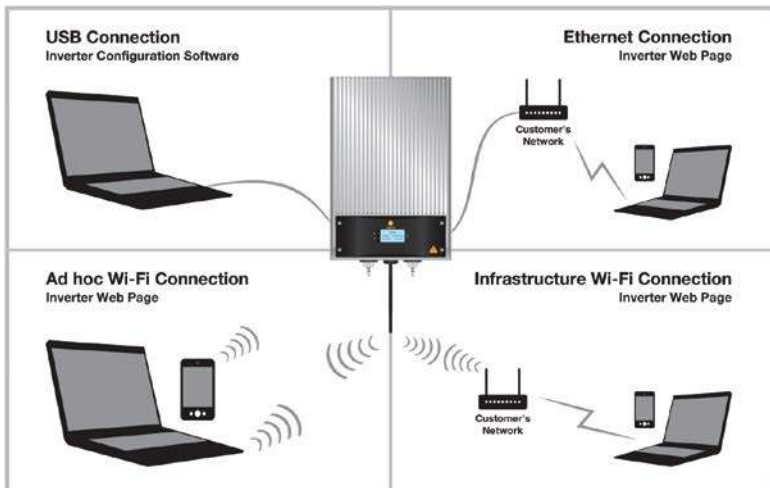

Connection & Configuration Methods

USB Connection: Is a direct wired connection between the installer's computer and the inverter. This method requires a USB Mini-B cable and the Inverter Configuration Software.

Ethernet Connection: Is a wired connection between the customer's network and the inverter. Configuration is carried out via the Inverter Web Page. This method is only applicable to the Ethernet inverter version.

Ad-hoc Wi-Fi Connection: Is a direct wireless connection between a Wi-Fi enabled device and the inverter. Configuration is carried out via the Inverter Web Page. Note that only certain devices and operating systems

support the ad-hoc mode, eg Android OS and Windows 8 and later do not support ad-hoc connection. **Infrastructure Wi-Fi Connection:** Is a wireless connection between the customer's network and the inverter. Initial configuration is required via either USB or Ad-hoc Wi-Fi connection. Further setup can be carried out using the Inverter Web Page.

Configuration is carried out to enable the customer to view the inverter's web page. The inverter will still operate without configuration.

Regardless of the connection method used, the following settings should be configured. There are also advanced settings available which are explained later in this manual.

Date, Time and Time Zone: The inverter contains a clock that is used to generate charts on the Inverter Web Page and internal log files.

Network Settings: Depending on your connection method and customer's network, some settings may need to be set/changed so that the inverter can connect to the customer's network.

Solar Panel Earthing: The required PV panel earth reference. See Configuration Details.

Inverter Name: Is a personalised name to be displayed at the top of the inverter's web page. If multiple inverters are installed on a site, each name must be unique. **This is required for compliance to AS/NZS 4777.2:2015: ensure it is enabled.**

Once the inverter has been configured, the inverter should be commissioned - see the [Commissioning the System](#) section.

Configuration Details

The DC switch must be turned 'ON' during configuration.

Solar Panel Earthing and advanced Grid Connect settings can only be changed using the Inverter Configuration Software through a USB connection.

Solar Panel Earthing options must be set as appropriate for each installation. See the [Earthing of Solar Arrays](#) section for more information:

Earth Fault Detection Enabled – Provided for diagnostic purposes only, should be left enabled.

DC – Installed Capacity – This is a free-form field that allows you to enter the peak capacity of your PV panels for future information.

Earthing Position – Set to either Positive, Negative, or Isolated, corresponding to the solar panel earthing selected in the [Earthing of Solar Arrays](#) section.

Inverter Generates With Fault – If this is selected, then the inverter will display an error, but continue to operate, if there is less than 50kΩ earth impedance detected.

The settings section of the Inverter Web Page requires a username and password known as the "Web Administrator Username/Password". The default username is 'Admin' and password 'Admin1', but these can be changed in the Network section of the Inverter Web Page, or in the Advanced Network tab in the Inverter Configuration Software. If the username or password is lost, see instructions for resetting the Web Administrator Username/Password in the [Troubleshooting](#) section.

An IP address is a numerical label assigned to each device on a network. From a device connected to the customer's network or directly to the inverter via Ad-hoc, the Inverter Web Page can be accessed by entering the inverter's IP address into a web browser (such as Chrome, Safari, Internet Explorer, etc.) as four numbers separated by dots e.g. <http://192.168.1.105>. When the inverter is connected to a network, its IP address will be displayed on the Network Screen – see the [Using the Inverter](#) section.

Most networks use DHCP to automatically assign an IP address to new devices connected to the network. The inverter is configured to use DHCP by default, so an IP address will generally not need to be manually set. If a static IP address needs to be assigned, this can be done in the Advanced Settings Network section of the Inverter Configuration Software.

The hostname is an alternative to entering the inverter's IP address. By default the hostname is ENASOLAR-GT, meaning the customer can enter <http://ENASOLAR-GT> into a web browser to view the Inverter Web Page. A hostname may be up to 15 characters long and cannot contain spaces. If multiple inverters are being installed the hostname should be unique for each inverter.

Inverter Configuration Software

The USB external connector has been fitted to all EnaSolar GT Inverters from 1 April 2016. This allows the system owner the option to re-configure the WiFi Network parameters without having to remove the inverter front-panel.

Please refer to separate user document (ref. 160201A), for information and instructions on how to utilise this connector to reconfigure these parameters.



A computer with Windows XP or later is required for USB configuration. Download and install the latest version of inverter configuration software from our website:

<https://www.enasolar.net/support/>.

Connect a USB cable between a computer and the 'USB Mini-B' socket on the back of the Display Module (or use the external USB connector) and then open the Inverter Configuration Software.



Connecting the USB Cable

The following should be set in the Setup menu:

- *Click to set Time* (include: Date and Time Zone), (this will set the inverter time to the same time as your connected computer. Ensure that the time and date are correct)
- *Inverter Name*
- *Solar Panel Earthing*.

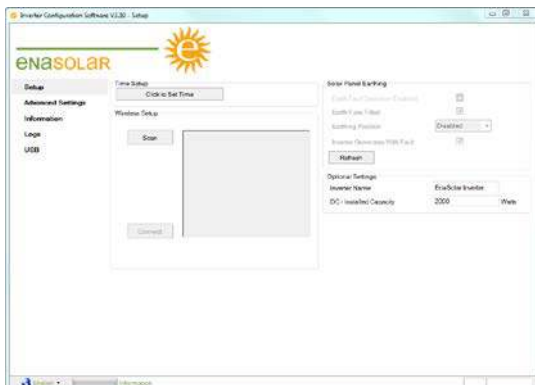

Optional Settings: Solar Panel Earthing, Inverter Name, DC Installed Capacity.

If a Wi-Fi inverter version is being installed, click the Scan button on the Setup page. A list of wireless networks within range of the inverter will be displayed. Select the customer's wireless network from the list and click the Connect button. The Inverter Configuration Software will prompt for any required Wi-Fi passwords.

If an Ethernet inverter version is being installed, further settings can be found in the Advanced Settings.

Configuration through the Inverter Web Page

Most settings in the inverter can be configured through the Inverter Web Page. Either of the three network connection methods can be used to access the Inverter Web Page; see the [Ethernet Connection](#), [Ad-hoc Wi-Fi Connection](#) or [Infrastructure Wi-Fi Connection](#) section for more information.

Using a device connected to the customer's network, or directly to the inverter via Ad-hoc, access the Inverter Web Page by entering the inverter's IP address into a web browser e.g. <http://192.168.1.105>. The Inverter Web Page has three sections; Home, Charts and Settings.

To access the Settings section, click on the Settings link and enter the username and password when prompted. By default, the username is: *Admin* and the password is: *Admin1*.

The Inverter Name should be set in the Network sub section and the time and date settings should be set in the Time sub section.

If a Wi-Fi inverter version is being installed, enter the customer's wireless network name, security mode and password in the Wireless sub section.

If an incorrect wireless network name, security mode or password is entered, the inverter will fail to connect to the network. If this happens an Ad-hoc connection will be available, which can be used to retry.

The Network sub section allows the inverter's advanced network settings to be changed. For more information on these settings see the [Configuration Details](#) section.

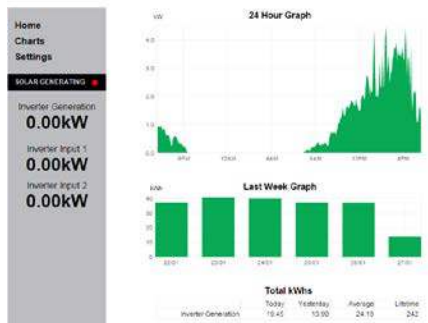

Example inverter webpage – without Immersun

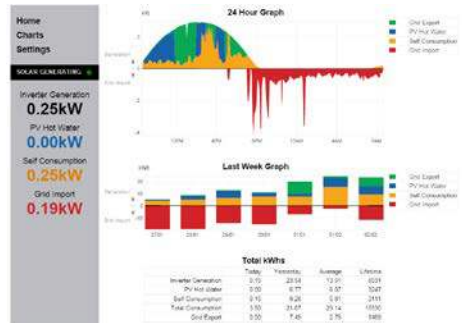

Example inverter webpage – with Immersun

Ethernet Connection

An Ethernet connection is a direct wired connection between the customer's network and the inverter. Ethernet connections require the Ethernet version of the inverter, rather than the standard Wi-Fi version.

Generally, there will be no additional network setup required for Ethernet connected inverters as the inverter is configured by default to common network settings (DHCP enabled). If the Display Module displays an IP Address in the Network Screen, the inverter has successfully connected to a network and configuration can proceed - see the [Configuration through the Inverter Web Page](#) section.

If the inverter fails to connect to an Ethernet network, use a USB connection to set the network settings as required by the customer's network administrator. Relevant settings are located in the Advanced Network section of the Inverter Configuration Software.

Ad-hoc Wi-Fi Connection

An Ad-hoc Wi-Fi connection is a direct wireless connection between a Wi-Fi enabled device and the inverter. Ad-hoc connections give access to the Inverter Web Page. For general use, an Infrastructure Wi-Fi connection (detailed below) is preferred, because only one device at a time can be connected to the inverter via Ad-hoc.

If the inverter fails to connect to a Wi-Fi network, or none is available, the inverter will become available for connection via Ad-hoc. When the inverter is available for Ad-hoc connection, a unique 5 digit key will be displayed on the inverter's Network Screen.



Ad-hoc Wi-Fi Connection Key



Ad-hoc Wi-Fi Connection (Mac OS)

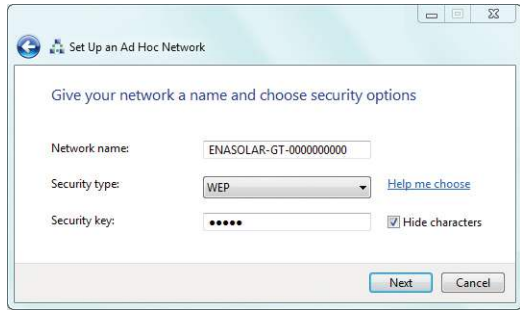

Ad-hoc Wi-Fi Connection (Windows)

The Ad-hoc network name for the inverter is based on the inverter's hostname. By default, the hostname is ENASOLAR-GT, so the default Ad-hoc network name is ENASOLAR-GT- followed by the inverter's 10 digit serial number. Connect to this network using a Wi-Fi enabled device and when prompted enter the 5 digit key displayed on the inverter.

When connected to the inverter via Ad-hoc, the Inverter Web Page can be accessed by entering the inverter's IP address into your web browser, as detailed in the [Configuration Details](#) section. Note that the inverter's IP address will default to 10.10.5.5 when connected via Ad-hoc. Note that only certain devices and operating systems support the ad-hoc mode, eg Android OS and Windows 8 and later do not support ad-hoc connection.

Default Ad-hoc Wi-Fi Settings:

IP Address:	10.10.5.5
Host Name:	ENASOLAR-GT
Wireless Network Name (SSID):	ENASOLAR-GT-xxxxxxxxxx (10 digit serial number).
Wireless Network Password:	5 digit key, displayed on the inverter's Network Screen.
Security Mode:	WEP with Open Authentication.

Infrastructure Wi-Fi Connection

Infrastructure Wi-Fi is the standard type of Wi-Fi connection. In this mode, the inverter will connect to the customer's wireless access point (or modem, router, etc.), which makes the inverter web page accessible to any device connected to the customer's network. Infrastructure Wi-Fi is preferred over Ad-hoc, since it allows for multiple devices to simultaneously access the Inverter Web Page.

Initial setup for infrastructure Wi-Fi requires some configuration through either an Ad-hoc or USB connection and the method will differ slightly depending on which is used. In either case, the following information will be required:

- Name of the customer's wireless network (SSID).
- Security Mode (encryption method) used by the customer's network (Open, WEP, or WPA).
- The customer's wireless password, if their network is encrypted.
- Authentication type (Open or Closed) if WEP security is used.

Infrastructure Wi-Fi Setup through a USB Connection

Follow the instructions in the [Inverter Configuration Software](#) section to connect with the inverter and start the Inverter Configuration Software.

On the "Setup" page, click the scan button to update a list of wireless networks within range of the inverter. Select the customer's wireless network from the list, and click the 'Connect' button. If you are prompted to, enter the customer's wireless network password.

WEP authentication type will be required when connecting to a network that uses WEP. If the WEP authentication type is unknown, Open will be correct in most cases

When the inverter has successfully connected to the Wi-Fi network, a message including the inverter's IP address will be displayed in the Inverter Configuration Software.

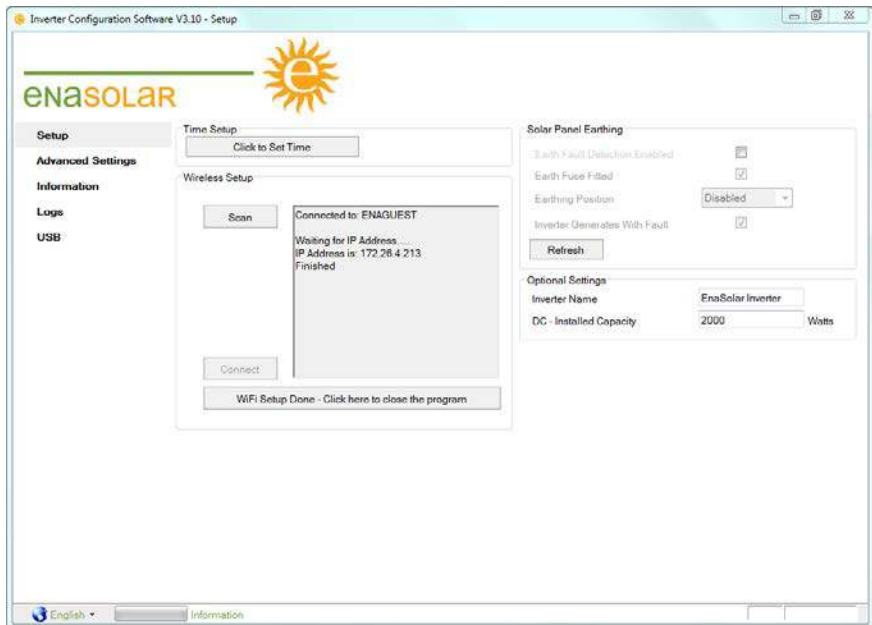

Infrastructure Wi-Fi Connection

Infrastructure Wi-Fi Setup through an Ad-hoc Wi-Fi Connection

Connect to the inverter as detailed in the [Ad-hoc Wi-Fi Connection](#) section. Once connected, access the Inverter Web Page as in the [Configuration through the Inverter Web Page](#) section. Fill in the appropriate information in the Wireless Network section of the Inverter Web Page. The inverter will attempt to connect to the newly specified network after the Apply Settings button is clicked. If the connection fails, the inverter will again be available for an Ad-hoc connection.

Note: If any of the above fails - refer to the [Network Troubleshooting](#) section. More advanced settings can be found on the advanced settings page.

6. COMMISSIONING THE SYSTEM

Fitting the Display Module

Remove the USB cable and place the Display Module on the Inverter Module, ensuring that no wires are pinched between the Wall Mount and the Display Module.

Tighten the top two screws on the Display Module then press in the bottom of the inverter before tightening the bottom two screws. Turn the AC and DC switches to the 'ON' position. If there is power from the solar array, the inverter will start generating. See the [Troubleshooting](#) section if an error is displayed.

Using the Inverter

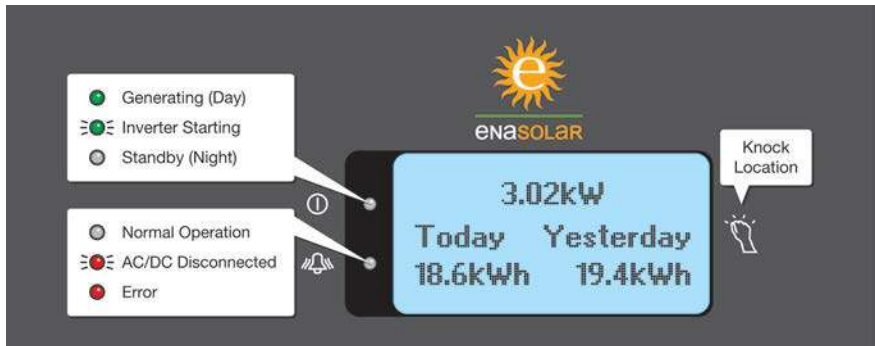

Display Module Notifications

Knock on the metal Display Module, not on the display itself, to navigate through the screens.

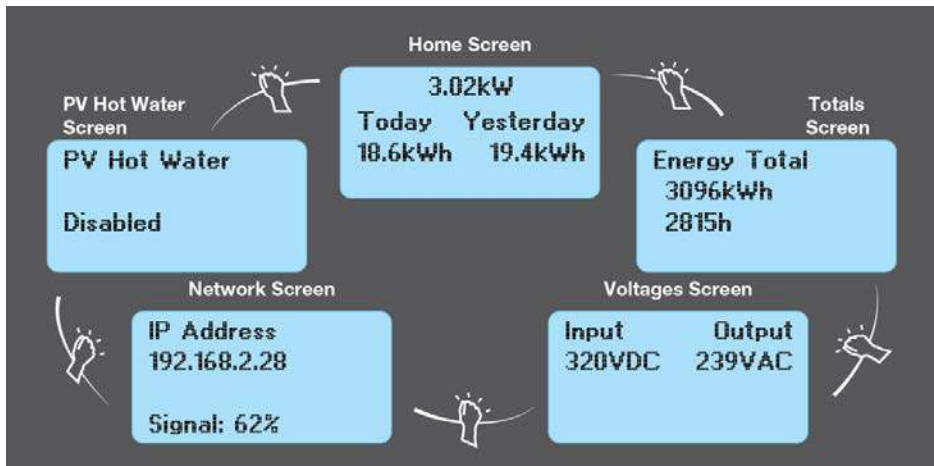

Display Module Navigation (note: screen text above is indicative only. Actual screen text will vary depending on model and system configuration)

The navigation screens show different aspects of the inverter's operation as detailed below:

- **Home Screen:** Current power production or status, today and yesterday's energy production.
- **Totals Screen:** Lifetime energy production and generating time.
- **Voltages Screen:** Input and output voltages.
- **Network Screen:** Inverters IP address, networking state, Ad-hoc password and/or Wi-Fi signal strength as appropriate.
- **PV Hot Water:** Current status of connection to Immersun system (if applicable)
- **Event Screen:** If an abnormal event occurs, an additional screen detailing the event will be displayed prior to the Home Screen.

Stopping the Inverter

Turn the AC and DC switches 'OFF'. The inverter will stop generating and the red LED will flash.

Maintenance

The inverter requires very little maintenance. Use a soft damp cloth to clean the outside of the inverter as required. Keep the Inverter Module free of cobwebs, leaves etc.

If the inverter is installed in a salty environment, gently rinse the inverter with a low pressure hose.

Other complete system maintenance (which may include more inverter items) is required to be completed at certain intervals, as defined in legislation. Please refer to your system documentation as it relates to your local standards.

Warranty Information

Warranty information is available on our website: <https://www.enasolar.net/products/>

EnaSolar will not be held responsible for indirect or consequential damages or lost profits, even if EnaSolar has been advised of the possibility of such damages. EnaSolar's sole obligation to you shall be the repair or replacement of a non-conforming product.

7. ADVANCED USAGE

The inverter maintains three log files internally, to track output and to aid in diagnostics in the event of a failure:

Daily Log: The amount of power produced each day and the amount of time spent exporting power to the grid.

5 Minute Log: Logs the output power every 5 minutes.

Event Log: Logs any unusual events that occur to diagnose potential faults. Blank lines mean that all events were cleared at that time.

The Daily Log and 5 Minute Log are available to the customer through the Inverter Web Page. The Event Log is intended only for use by EnaSolar and certified installers. All three logs are available through the Inverter Configuration Software in the Logs page.

To read logs through the Inverter Web Page, click the Export Daily Log or Export 5 Minute Log button at the bottom of the Charts section. The log file will be downloaded to your computer as a Comma Separated Value (.CSV) file, which can be opened in spread sheet software.

Advanced Settings

Several tabs are available in the Advanced Settings page of the Inverter Configuration Software. These tabs contain settings that might be relevant in certain circumstances. These settings will generally not need to be changed. Please contact EnaSolar for more information about these technical settings.

Advanced Settings - Network

The Network Connection Details section shows the current details for the inverter's network interface. The Network Settings section allows the inverter network interface settings to be changed.

If DHCP is disabled then the Default IP Address, Default Subnet Mask, Default Gateway, Default Primary DNS Server and Default Secondary DNS Server will need to be set manually. The Gateway and DNS should usually be set to the local IP address of the router or access point.

The Web Administrator Username and Password that are used to log into and gain access to the settings web pages can be changed using this screen. Consult the customer for their preference.

The Wireless Settings section allows the wireless settings to be changed at a lower level than is generally required. Changing the region and deselecting scan channels is not advised.

Advanced Settings - Grid Connect

Grid connect settings control the limits of AC mains quality where the inverter will output power. The inverter will disconnect if it detects that the AC voltage or frequency goes outside the limits defined for specified amounts of time.

Default grid connect settings are based on regulations in effect for the country where the inverter is sold. These limits can usually be changed, but permission from the relevant electricity distributor will be required. Contact EnaSolar (support@enasolar.net or +64-3-366 4550) for more information on changing Grid Connect Settings, if required.

Advanced Settings - Other

Stop Red LED Flashing – After the inverter is powered on for the first time, if both AC mains and the DC supply are disconnected (or switched 'OFF'), the red LED on the Display Module will periodically flash. Normally, this indicates that there is a mains fault and no DC supply. If, however, the Display Module needs to be stored for several weeks, this flashing would eventually drain the small battery in the Display Module. When long term storage of the Display Module is required, the "Stop LED" button can be pressed, which will prevent the red LED from flashing once power is disconnected. The red LED will resume normal operation upon next power up.

Totals section - Two boxes allow the total energy output and time generating to be changed. This feature is useful if the Display Module requires replacement.

Copy Display Module Settings and Daily Log - This section is used to backup and restore the settings from the inverter's Display Module. Use the Read button to store these settings as a file on your computer, or the Write button to write the file back to a Display Module. This feature is intended for duplicating network settings for multi-inverter installs, or for backing up the Daily Log in case the Display Module requires replacement.

Several settings pertaining to MPPT are available on newer inverters (see the EnaSolar website for application notes as required). Please contact EnaSolar for more information about these technical settings.

8. TROUBLESHOOTING

Installer Serviceable Components

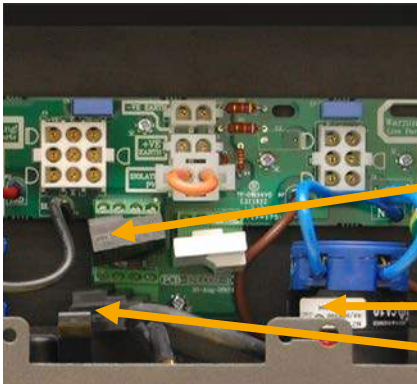

MOV (-ve to +ve)

MOV (AC protection) P to N

MOV (-ve to earth)

Installer Serviceable Components 1.5kW to 3.8kW Inverter Models

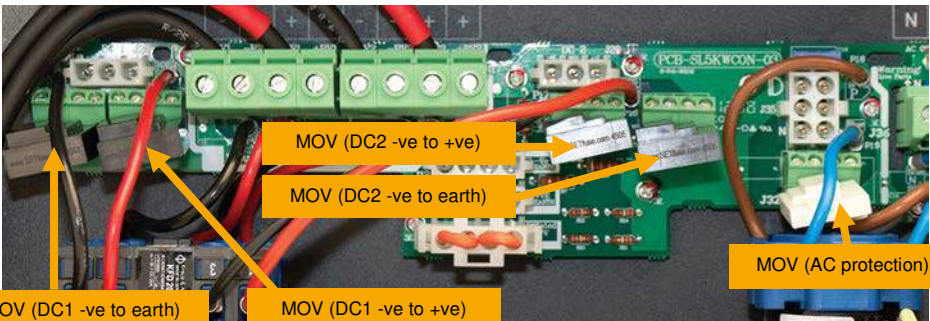

MOV (DC2 -ve to +ve)

MOV (DC2 -ve to earth)

MOV (AC protection)

MOV (DC1 -ve to earth)

MOV (DC1 -ve to +ve)

Installer Serviceable Components 4.0/5.0kW Inverter Models



WARNING - Risk of Electric Shock.

Take care when removing the Display Module. There is live AC and DC power on the wiring terminals.

To remove the Display Module (which also acts as the Wall Mount cover):

- Turn the AC and DC switches to the 'OFF' position.
- Remove the two captive screws on the left-hand and right-hand side of the cover and carefully remove the Display Module out for access to the connectors.
- Disconnect the 4 way connector, the wireless coaxial connector and the earth connector.
- Carefully set aside the Display Module.



WARNING - Risk of Electric Shock.

Take care when replacing the Display Module. There is live AC and DC power on the wiring terminals.

To replace the Display Module:

- Ensure the AC and DC switches are in the 'OFF' position.
- Connect the 4 way connector, the wireless coaxial connector and the earth connector.
- Place the cover on the Inverter Module, ensuring that no wires are pinched between the Wall Mount and the cover.
- Replace the two captive screws on the left-hand and right-hand side of the cover and tighten securely.

If a replacement Display Module is required to be fitted, the historic data that has been saved on the older unit can be transferred by using the transfer function on the Inverter Configuration Software. This can be found within the 'Advanced Settings' page under the tab labelled 'Other'.

General Troubleshooting

NO DC: Check that the DC switch is turned 'ON', the solar array is fully exposed to sunlight and the polarity of the DC input.

NO AC: Check that the AC switch is turned 'ON' and the AC circuit breaker is on at the switchboard.

PV Earth Fault: Isolated Earth - this means there is less than 50k Ω between the positive or negative DC input and earth. That is the cabling for the solar array has developed a fault from either the positive or negative input to ground. This will display the message 'PV Earth Fault' and will continue to operate.

Although the inverter will continue to operate as an isolated earth installation, this is a fault that needs to be urgently addressed. A 'PV Earth Fault' does not necessarily indicate an unsafe situation, but a subsequent fault could result in a fire and safety risk.

Possible causes:

- Faulty cell in one of the solar modules.
- Cracked/corroded/damage solar module.
- Chaffed or damaged wiring.
- Incorrect wiring or configuration.
- Water between connections.

The inverter has internal impedances, so before making any impedance measurements ensure the DC switch is turned 'OFF'. To help diagnose where the problem lies, while the inverter is running, measure the following voltages: positive to negative, positive to ground and negative to ground. By comparing these values, this will give an indication where the problem lies.

PV Earth Fuse: Positive or negative earth - If this alarm is generated, a current greater than 1A has blown the Earth Fuse. Once the fault has been rectified, the fuse will need to be replaced. See below for the procedure.



WARNING - Risk of Electric Shock.

The PV Earth Fuse must only be replaced by a trained solar technician.

- Ensure the AC and DC switches are turned 'OFF'.
- De-energise both the AC (from the switchboard) and DC (Solar array) feeds into the inverter.
- Gain access to the Wall Mount by removing the Display Module.
- Check if the Earth Fuse is open and leave the fuse holder open.
- Inspect the solar array for any possible cause of the fault and remedy as required.
- Replace the fuse with - 1A, 600V DC Littlefuse KLKD 1
- Refit the Display Module and re-energise the system.



Note, the above is only on older versions. Earlier versions of the 1.5-3.8kW models incorporate a separate earth fuse

MOV Fail

Metal oxide varistors (MOV) are used in EnaSolar inverters to provide some protection to the other components in the event of an electrical surge. If a sudden surge comes down the cable, then the MOV directs this energy to the "ground", rather than onwards to the more sensitive internal components. The metal oxide material inside the MOV is permanently damaged in the process.

When a MOV has been damaged sufficiently, the Inverter will keep operating as normal and an error message will remain displayed on the LCD until resolved. Because they are located on live circuitry, a qualified service-person is required to conduct the testing and replacement.



WARNING - Risk of Electric Shock.

MOV protection devices must only be replaced by a trained solar technician.

- Ensure the AC and DC switches are turned 'OFF'.
- Gain access to the Wall Mount by removing the Display Module.
- Inspect each of the MOV's fitted in the system by measuring continuity on the middle two leads. An open circuit indicates that the MOV has failed:
 - two DC protection: negative - positive and negative - earth.
 - one AC protection: phase - neutral.
- Replace any defective MOV's. Spare MOV's are available from your EnaSolar distributor.
- Refit the Display Module and re-energise the system.
- If the MOV fail alarm still exists, contact the EnaSolar service department.

Note: The MOV fail alarm will be generated when any of the MOVs have failed (the sensing devices are all connected in series).

If the software fails to find the inverter, click the scan button at the bottom of the page to initiate the connection.

All Wi-Fi Issues: If the signal strength is less than 30%, move the access point closer to the inverter if possible and/or try an enhanced antenna on either the inverter or access point, or both.

Check the access point is configured in 'mixed mode' with 'b' compatibility enabled.

A repeater may need to be installed if the access point cannot be moved closer. Consult your IT specialist for further details.

Access Point Not Found: Check that the access point is switched on. Check the antenna connections on the inverter and access point. Move the access point and inverter closer together if possible.

Security Not Matched: Check that the wireless security settings match with the access point.

Failed to Join Network: Check that the wireless settings match with the access point.

Failed to Authenticate: Check that the WEP key and WEP authentication type, or WPA passphrase, match with the access point.

Failed to Associate: Check the WEP key and WEP authentication type, or WPA passphrase, match with the access point. Check that MAC filtering is not enabled on the access point. If it is then disable it, or add the MAC address of the inverter to the allowed list.

Ad-hoc Connected: A user is connected to the inverter by the Ad-hoc connection.

Failed to get an IP Address: If there is no DHCP server on the network, disable DHCP and manually enter the default IP address, DNS IP and Gateway IP in the advanced settings page of the Solar Inverter Configuration Software.

If there is a DHCP server on the network, then the user's access point may be transmitting wireless broadcasts at the wrong rate. Change the base transmit rate of the access point to 2 Mb/s. Look at the documentation for the access point on how to do this. Otherwise set the inverter to have a static IP and manually enter the default IP address, DNS IP and gateway IP in the advanced settings page of the Solar Inverter Configuration Software.

Web page can't be accessed using the IP address: Check that the IP address has been entered correctly and that both the inverter and computer from which the web page is being accessed are successfully connected to the same network.

Web page can't be accessed using the Host Name as the address: Try to access the web page using the IP address displayed on the network page on the Display Module. If the IP address gives access to the inverter web page, but the host name does not, then your device or web browser may not support the protocol used to access the inverter by hostname.

Lost or Forgotten Password: The username and password 'Admin' and 'Admin1' will always allow access to the Settings section of the Inverter Web Page when connected via Ad-hoc - see Ad-hoc Wi-Fi Connection section. Once connected, the web administrator username and password can be changed in the Network Settings section.

Since the inverter will not be available for Ad-hoc connections while it is connected to an Infrastructure Wi-Fi network, the inverter may first need to be disconnected from the customer's Wi-Fi network. The simplest approach is to turn off the customer's Wi-Fi access point (router, modem, etc.) until an Ad-hoc connection with the inverter has been established.

9. UNDERSTANDING THE PART NUMBER

Example: 1.5kWGT-AUNZE

1.5kW: Nominal output power.

GT: Grid tied.

AUNZ: This is the country identifier which has the specific parameters for the grid connect settings for that country. AUNZ (Australia/New Zealand) uses the same settings as they are both governed by the AS4777 regulations. For the UK (United Kingdom) the settings are governed by the G83/1-1 regulations.

E: Identifies the inverter is fitted with the Ethernet version of Display Module. There are two versions of Display Module: Ethernet and Wi-Fi. Wi-Fi is standard and if fitted there will be no 'E' in the part number. E.g. 1.5kWGT-AUNZ.

10. GLOSSARY

Nm	Newton metre.	DC	Direct current.
LED	Light emitting diode.	MOV	Metal oxide varistor.
Lb-In	Pounds-inches.	GFDI	Ground fault detector interrupter. A fuse between earth and a solar panel DC output that interrupts excessive fault current.
LCD	Liquid crystal display.		
PV	Photovoltaic.		
AC	Alternating current.		

11. TECHNICAL SPECIFICATIONS

DC Input:	1.5kW	2.0kW	3.0kW	3.8kW	4.0kW	5.0kW
Number of Inputs:	1x MPPT input			2x independent MPPT inputs		
Maximum Open Circuit Voltage (V _{oc}):	50V	60V	60V	50V	60V per DC input	
DC Full Power Operating Range:	150-450V	189-500V	215-500V	246-350V	200-500V per DC input	238-500V per DC input
Operating Voltage Range (V _{mpp}):	120-450V	120-450V	120-500V	120-400V	120-500V per DC input	
DC Optimal Operating Voltage:	300V DC	350V DC	375V DC	275V DC	350V per DC input	
Maximum Input Current (I _{mpp}):	11.0A	12.0A	15.0A	16.5A	15.0A per DC input	
Maximum Short Circuit Current (I _{sc}):	12.5A	13.5A	16A	19A	16A	
Maximum Usable Input Power (P _{max}):	1640Wp	2200Wp	3200Wp	4000Wp	3000Wp per DC input	3500Wp per DC input
Maximum Allowable Input Power:	2250W	3000W	4500W	5000W	6000W total	7000W total
Reverse Polarity Protection:	Inherent crowbar diodes					
Isolation From AC Mains:	Galvanically isolated high frequency transformer					
Earthing:	Isolated, +ve earth, -ve earth selectable					
AC Output:	1.5kW	2.0kW	3.0kW	3.8kW	4.0kW	5.0kW
Nominal Output Voltage:	230V AC single phase					
Output Voltage Range:	202-259V AC (AU/NZ), 208-262V AC (UK)					
Output Power:	1500W	2000W	3000W	3800W 3690W (UK)	4000W	4990W 4600W (AU4,6)
Max Output Current:	7.5A	10.0A	15.0A	16.0A	18.0A	21.5A 21.0A (AU4,6)
Recommended AC Circuit Breaker Size:	16.0A		20.0A		32.0A	
Line Frequency:	50Hz					
Total Harmonic Distortion:	<5% at full load, nominal output voltage					
Max Efficiency:	>96.0%	>96.0%	>96.4%	>96.0%	>96.8%	>96.8%
Max Euro Efficiency:	>93.8%	>94.3%	>94.5%	>94.5%	>94.8%	>95.4%
Power Factor:	>0.98 (30 -100% load)					
System:	1.5kW	2.0kW	3.0kW	3.8kW	4.0kW	5.0kW
Islanding Protection:	AS/NZS 4777.2:2015					
	G83/2			G59/2		
Night-time Consumption:	<1.2W					
Operating Temperature Range:	-30°C to +50°C (full power), 40°C for 3.8kW, +70°C (derated)					
Acoustic Noise:	<33dBa @ 1m					
Max Humidity:	100%					
Max Altitude:	2000m					
Display:	4 line x 16 character (no buttons)					
Data Interface:	Wi-Fi IEEE 802.11 (optional Ethernet RJ45) web server built-in for EnaSolar Online remote monitoring and reporting					
Environmental Rating:	IP55 suitable for outdoor, wet locations					
Dimensions:	330mm x 550mm x 145mm (excluding antenna)			401mm x 600mm x 168mm (excluding antenna)		
Weight:	14kg		15kg		20kg	
Compliances:	C-Tick, CE (refer to website for full product standards matrix)					
Pollution Degree:	3					
Over Voltage Category:	Cat III					
AC Mains:	Cat II					
DC Input:	0					
Max Backfeed Current:	0					
Max Output Fault Current (Continuous RMS):	7.5A	10.0A	15.0A	16.0A	18.0A	21.5A



ena**SOLAR**

Manufactured by: EnaSolar Limited

66 Treffers Road, Christchurch 8042, New Zealand

Tel +64-3-366 4550 | Fax +64-3-366 0884

www.enasolar.net