



# IQ8 Series Microinverters

Our newest IQ8 Series Microinverters are the industry’s first microgrid-forming\* microinverters. The high-powered, smart grid-ready IQ8 Series Microinverters are designed to match the latest-generation high-output PV modules. IQ8 Series Microinverters have the highest energy production and reliability standards in the industry, and with rapid shutdown functionality, they meet the highest safety standards. The brain of the semiconductor-based microinverter is our proprietary, application-specific integrated circuit (ASIC) which enables the microinverter to operate in grid-tied or off-grid modes. This chip is built in advanced 55-nm technology with high-speed digital logic and has superfast response times to changing loads and grid events, alleviating constraints on battery sizing for home energy systems.



### IQ Gateway

The IQ Gateway is the platform for energy management and integrates with IQ Microinverters and IQ Batteries to provide complete control and insights into the Enphase Energy System.



**IQ Relay single-phase and multi-phase**  
Production and storage circuit, integrated Neutral Sensing-protection device with PLC-Phase coupler (multi-phase) and DC current injection monitoring.

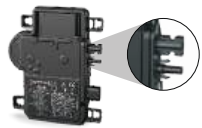

### Integrated MC4 connectors

Connect PV modules quickly and easily to the IQ8 Series Microinverters that have integrated MC4 connectors.

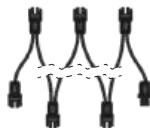

### IQ Cabling

Install microinverters quickly and safely with IQ Cabling. With multi-phase IQ Cabling, the installed capacity is automatically distributed evenly across all three phases.



### 25-year limited warranty

IQ8 Series Microinverters redefine reliability standards with more than 1 million cumulative hours of power-on testing, enabling an industry-leading limited warranty of up to 25 years.\*\*



### IQ Battery 5P

Part of the Enphase Energy System, the IQ Battery 5P integrates with the IQ8 Series Microinverters, IQ System Controller 3 INT, and the Enphase App monitoring and analysis software.

### Compatible with latest-generation high-output PV modules

- Supports latest high-current PV modules
- IQ8 Series Microinverters support all common PV module powers and cell architectures

### Easy to install and commission

- Lightweight and compact with integrated Stäubli MC4 connectors for easy installation
- Fast installation with simple AC cabling
- New integrated circuit technology enables faster firmware upgrades

### High-energy production, reliability, and safety

- Produce power even when the grid is down\*
- More than 1 million power-on hours of reliability testing
- Patented Burst Mode technology provides increased energy production
- Low-voltage DC and rapid shutdown for the ultimate fire safety

#### NOTE:

Commissioning of IQ8 Series Microinverter systems requires Enphase Installer App version 3.31.0 or higher. IQ8 Series Microinverters cannot be mixed together with previous generations of Enphase microinverters (IQ7 Series, IQ6 Series) on the same IQ Gateway.

\* Only when installed with IQ System Controller 3 INT and IQ Battery 5P.

\*\* A 25-year limited warranty is valid, provided an internet-connected IQ Gateway is installed.

# IQ8 Series Microinverters

INPUT DATA (DC)		UNITS	IQ8AC-72-M-INT		IQ8HC-72-M-INT	
Typical module compatibility	—	—	54-cell/108-half-cell, 60-cell/120-half-cell, 66-cell/132-half-cell, 72-cell/144-half-cell No enforced DC/AC ratio and the maximum input power. Modules can be paired as long as the maximum input voltage is not exceeded and the maximum input current of the inverter at the lowest and highest temperatures is respected. See the module compatibility calculator at: <a href="https://enphase.com/en-au/installers/microinverters/calculator">https://enphase.com/en-au/installers/microinverters/calculator</a> !			
Minimum/Maximum input voltage	$U_{dc,min}/U_{dc,max}$	V	18/60			
Start-up input voltage	$U_{dc,start}$	V	22			
Rated input voltage	$U_{dc,r}$	V	36.5	37.0		
Minimum/Maximum MPP voltage	$U_{mpp,min}/U_{mpp,max}$	V	28/45	29.5/45		
Minimum/Maximum operating voltage	$U_{op,min}/U_{op,max}$	V	18/58			
Maximum input current	$I_{dc,max}$	A	14			
Maximum short-circuit DC input current	$I_{sc,max}$	A	25 Maximum short-circuit current for modules ( $I_{sc}$ ) allowed being paired with IQ8 Series Microinverters: 20 A (calculated with 1.25 safety factor as per IEC 62548).			
Maximum input power <sup>1,2</sup>	$P_{dc,max}$	W	480	505		
OUTPUT DATA (AC)		UNITS	IQ8AC-72-M-INT		IQ8HC-72-M-INT	
Maximum apparent power	$S_{ac,max}$	VA	366	384		
Rated apparent power	$P_{ac,r}$	VA	360	380		
Nominal grid voltage	$U_{ac,nom}$	V	230			
Minimum/Maximum grid voltage	$U_{ac,min}/U_{ac,max}$	V	184/276			
Rated/Maximum output current	$I_{ac,max}$	A	1.57/1.59	1.65/1.67		
Nominal frequency	$f_{nom}$	Hz	50			
Minimum/Maximum frequency	$f_{min}/f_{max}$	Hz	45/55			
Maximum units per single-phase 20 A circuit	—	—	11 (L+N) Single-phase	39 (3L+N) Multi-phase	10 (L+N) Single-phase	36 (3L+N) Multi-phase
Maximum units per multi-phase 25 A circuit	—	—	For IQ Cable with 2.5 mm <sup>2</sup> stranded conductors and using a 1.20 safety factor. The safety factors applied may vary based on local regulations or best practices, as well as upon the characteristics the OCPD selected.			
Recommended maximum units per single/multi-phase IQ Cable section to reduce voltage rise in IQ Cable	—	—	8 (L+N) Single-phase	18 (3L+N) Multi-phase	8 (L+N) Single-phase	18 (3L+N) Multi-phase
Protective class (all ports)	—	—	II			
Total harmonic distortion	—	%	<5			
Power factor setting	—	—	1.0			
Power factor range	cos phi	—	0.8 leading ... 0.8 lagging			
Inverter maximum efficiency	$\eta_{max}$	%	97.3	97.4		
European weighted efficiency	$\eta_{EU}$	%	96.6	96.8		
Inverter topology	—	—	Isolated (HF Transformer)			
Nighttime power loss	—	mW	50			
MECHANICAL DATA		UNITS	IQ8AC-72-M-INT		IQ8HC-72-M-INT	
Ambient air temperature range		°C (°F)	-40 to 60 (-40 to 140)			
Relative humidity range		%	4 to 100 (condensing)			
Overvoltage class AC port/DC port		—	III/II			

<sup>1</sup> Installer should not exceed the small-scale technology certificate (STC) limit on PV module wattage for claiming the STC.

<sup>2</sup> Pairing PV modules with wattage above the limit may result in additional clipping losses. See the compatibility calculator at <https://enphase.com/en-au/installers/microinverters/calculator>.

MECHANICAL DATA	UNITS	IQ8AC-72-M-INT	IQ8HC-72-M-INT
Number of input DC connectors (pairs) per single MPP-tracker	–		1
AC connector type	–	IQ Cabling (refer to the IQ Cable and accessories data sheet)	
DC connector type	–	Stäubli MC4	
Dimensions (H × W × D)	mm (in)	212 (8.3) × 175 (6.9) × 30.2 (1.2) (without mounting brackets)	
Weight (with mounting plate)	kg (lb)	1.1 (2.4)	
Cooling	–	Natural convection – no fans	
Enclosure	–	Class II double-insulated, corrosion-resistant polymeric enclosure	
IP rating	–	Outdoor - IP67	
Altitude	m	<2,600	
Calorific value	MJ/unit	37.5	

STANDARDS	IQ8AC-72-M-INT	IQ8HC-72-M-INT
Grid compliance (with IQ Relay)	AS/NZS 4777-2:2020	
Safety	EN IEC 62109-1, EN IEC 62109-2	
EMC	EN IEC 61000-3-2, 61000-3-3, 61000-6-2, 61000-6-3, EN IEC 50065-1, 50065-2-1, EN55011 <sup>3</sup>	
Product labelling	CE, RCM	
Advanced grid functions <sup>4</sup>	Power export limiting (PEL), phase imbalance management (PIM), loss of phase detection (LOP), power factor control Q (U), cos (phi) (P)	
Microinverter communication	Power line communication (PLC) 110–120 kHz (Class B), Narrowband 200 Hz	

<sup>3</sup> At STC within MPP range.

<sup>4</sup> Some of these functions require IQ Gateway Metered with current transformers and/or IQ Relay installed.

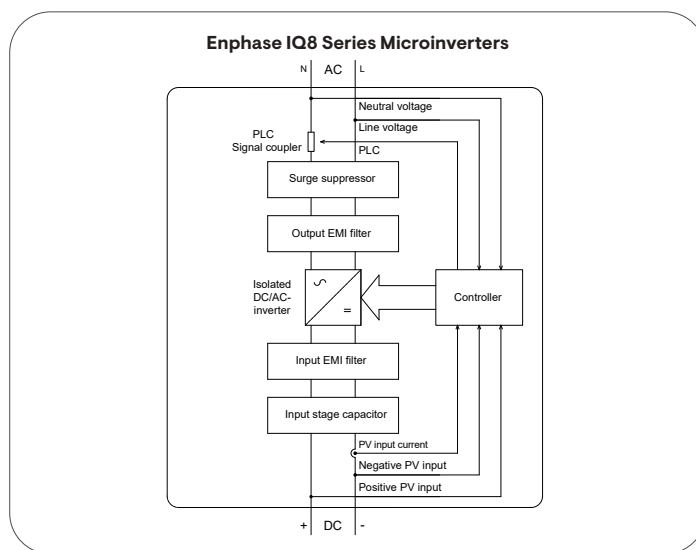
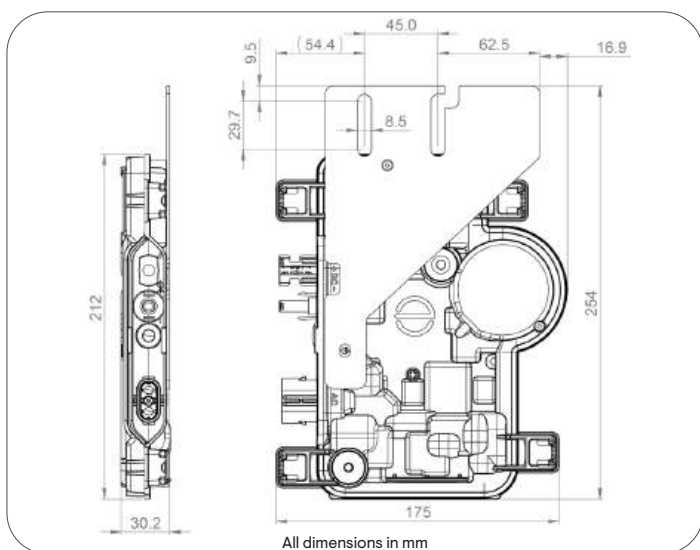
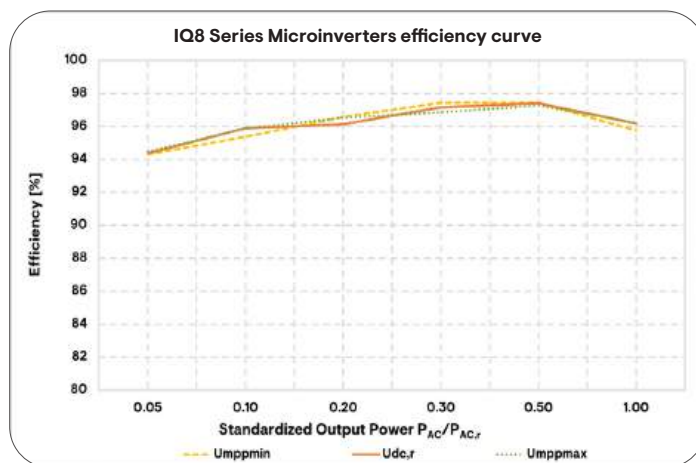
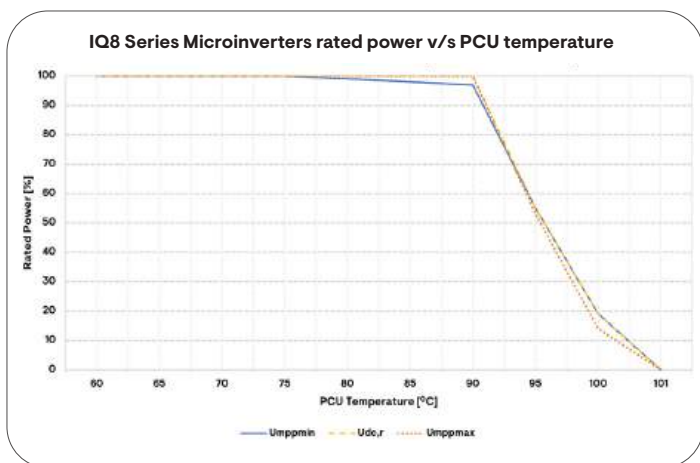

# Revision history

REVISION	DATE	DESCRIPTION
DSH-00004-4.0	October 2024	Updated the warranty from 15 to 25 years.
DSH-00004-3.0	July 2023	<ul style="list-style-type: none"><li>Added rated apparent power, rated output current, and over-voltage class DC port details.</li><li>Modified ambient air temperature range: -40°C to 60°C.</li><li>Removed extended warranty details from the data sheet. For an extended warranty, contact Enphase Support.</li></ul>
DSH-00004-2.0	May 2023	Initial release.
DSH-00004-1.0	April 2023	Preliminary release.