

Solar inverters

ABB string inverters PVI-10.0-I-OUTD 10kW



Designed for commercial systems, the PVI-10.0, isolated, three-phase inverter is highly unique in its ability to control the performance of the PV panels, especially during periods of variable weather conditions.

The dual Multiple Power Point Tracker (MPPT) maximizes energy production and increases design flexibility.

This dual independent MPPT functionality enables optimal energy harvesting from two sub-arrays oriented at different azimuths, tilts and varying string lengths. The wide input voltage range makes this inverter suitable for installations with a reduced string size.

The flat efficiency curves offer high efficiency at all output levels ensuring consistent and stable performance across the entire input voltage and output power range.

This inverter is feature rich, enabling the desired design flexibility to master any design challenge.

The input voltage range makes this inverter suitable for installations with reduced string size.

The PVI-10.0-I is built to endure harsh environmental conditions with its NEMA 4X rating.

The PVI-10.0-I is available with an optional fully-integrated DC combiner box equipped either with DC or AC and DC disconnect switches and DC fuses.

Highlights:

- This isolated inverter is available in 208V, 480V and 600V outputs.
- It has an efficiency rating of up to 97.3%.
- The high-speed and precise MPPT algorithm enables real-time power tracking and improved energy harvesting.
- The electrolyte-free power converter increases the life expectancy and reliability.

Power and productivity
for a better world™





Additional highlights:

- True three-phase bridge topology for DC/AC output conversion
- It features a night wake up button to access energy harvesting data and information when inverter is sleeping
- The dual independent MPPT allows optimal energy harvesting from two sub-arrays oriented in different azimuths and tilts
- NEMA 4X outdoor enclosure for use under any environmental conditions
- Integrated combiner box equipped with a DC switch in compliance with international standards (-S1,-S2)
- RS-485 communication interface (for connection to laptop or datalogger)

Technical data and types

Type code	PVI-10.0-I-OUTD-US			PVI-10.0-I-OUTD-CAN	
Nominal output power	10000W	10000W	10000W	10000W	10000W
Maximum output power	11000W*	11000W*	10000W*	10000W*	10000W*
Rated grid AC voltage	208V	480V	208V	480V	600V
Input side (DC)					
Number of independent MPPT Channels	2; programmable for 1 MPPT				
Maximum usable power for each MPPT channel	6800W				
Absolute maximum voltage (Vmax)	520V				
Start-up voltage (Vstart)	200V (adj. 120V min.)				
Full power MPPT voltage range	220-470V				
Operating MPPT voltage range	0.7 x Vstart - 520				
Maximum current (I _{dcmax}) for both MPPT in parallel	48A				
Maximum usable current per MPPT channel	24A				
Maximum short circuit current (I _{sc max.}) per MPPT channel	29A				
Maximum short circuit current (I _{sc max.}) for both MPPT in parallel	58A				
Number of inputs (strings) per MPPT channel	Standard version: 2; -S1 version: 3; -S2 version: 3				
Array wiring termination type	Terminal block, pressure clamp, 20AWG-6AWG				
Output side (AC)					
Grid connection type	3Ø/4W + Ground				
Default voltage range	183-228V	422-528V	183-228V	422-528V	528-660V
Nominal grid frequency	60Hz				
Adjustable grid frequency range	57-63 Hz				
Maximum Current (I _{ac max/phase})	30.0A _{RMS}	14.0A _{RMS}	30.0A _{RMS}	14.0A _{RMS}	10.6A _{RMS}
Power factor	>0.995 (adj. ±0.9)				
Total harmonic distortion (at rated power)	<2%				
Grid wiring termination type	Terminal block, pressure clamp, 12AWG-4AWG				
Fault current	44.4A _{RMS}	30.6A _{RMS}	44.4A _{RMS}	30.6A _{RMS}	18.65A _{RMS}
Input protection devices					
Reverse polarity protection	Yes				
Over-voltage protection type	Varistor, 2 for each channel				
PV array ground fault detection	GFDI (GFD fuse) per UL 1741/ NEC 690.5				
Output protection devices					
Anti-islanding protection	Meets UL 1741 / IEEE1547 requirements				
Over-voltage protection type	1 varistor per line (3), 1 gas arrester to PE				
Efficiency					
Maximum efficiency	96.5%	97.3%	96.5%	97.3%	97.3%
CEC efficiency	96.0%	97.0%	96.0%	97.0%	97.0%
Operating parameters					
Feed-in power threshold	30W _{RMS}				
Stand-by consumption	<8W _{RMS}				
Communication					
User-interface (display)	16 characters x 2 lines LCD display				
Standard communication interfaces	(1) RS485 connection. Standard Aurora protocol. Optional Modbus				
Optional remote monitoring logger	VSN 700 Data Logger				
Environmental					
Ambient air operating temperature range	-13°F to +140°F (-25°C to +60°C) Derating above +104°F (+40°C)	-13°F to +140°F (-25°C to +60°C) Derating above +122°F (+50°C)	-13°F to +140°F (-25°C to +60°C) Derating above +104°F (+40°C)	-13°F to +140°F (-25°C to +60°C) Derating above +122°F (+50°C)	-13°F to +140°F (-25°C to +60°C) Derating above +113°F (+45°C)
Ambient storage temperature range	-40°F to +176°F (-40°C to +80°C)				
Relative humidity	0-100 % condensing				
Acoustic noise emission level	<50 db (A) @ 1m				
Maximum operating altitude without derating	6560ft (2000m)				

*Capability enabled at nominal AC voltage and with sufficient DC power available

Block diagram of PVI-10.0-I-OUTD

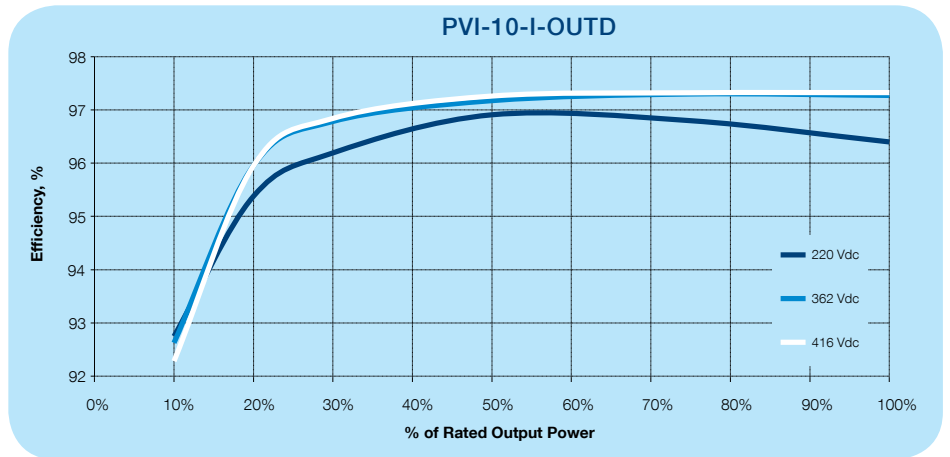
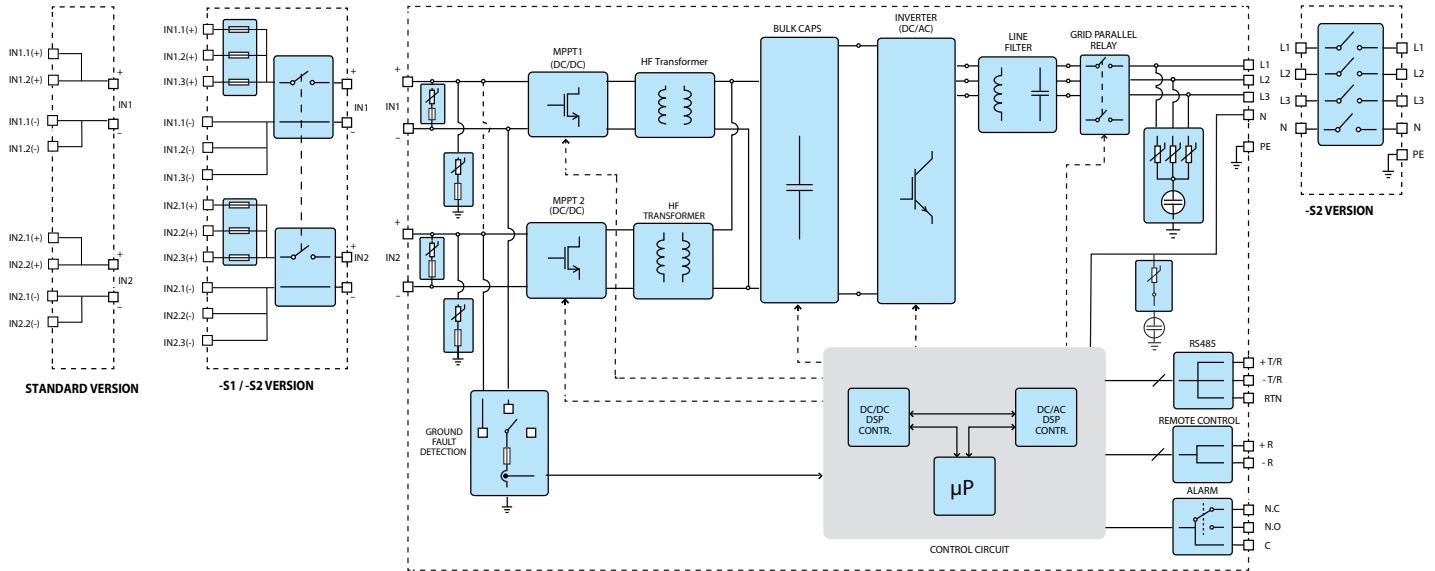

Technical data and types

Type code	PVI-10.0-I-OUTD-US	PVI-10.0-I-OUTD-CAN
Mechanical specifications	NEMA 4X	
Enclosure rating	Natural convection	
Cooling	Standard: 28.2 x 25.4 x 8.7in / 716 x 645 x 222mm -S1, -S2 version: 37.7 x 25.4 x 8.7in / 958 x 645 x 222mm	
Dimensions H x W x D	Standard: 101lb (45.8kg); -S1: 107 lb (48.5kg); -S2: 114lb (51.7kg)	
Unit weight	With pallet: 254lb (<115kg); without pallet: 143lb (<65kg)	
Shipping weight	Bottom: (1) 1/2" KO, (2) 1" pluggable opening, (4) 1/2" pluggable openings / Left and right Side: (1) Concentric KO 3/4", 1" / Back: (4) Concentric KO 3/4", 1"	
Conduit connections	Wall bracket	
Mounting system	1A / 600V	
Ground fault detector fuse size/type	10 x 38mm	
Optional string combiner fuse size/type (-S1 and -S2)	15A / 600V	
Optional DC switch current rating (per contact)	10mm x 38mm 32A	
Safety	Isolated - high-frequency transformer	
Isolation level	UL 1741, IEE1547, IEE1547.1, CSA-C22.2N. #107.1-01	
Safety and EMC standard	CSA	
Safety approval		
Available models		
Standard	PVI-10.0-I-OUTD-US-208-NG	PVI-10.0-I-OUTD-US-480-NG
	PVI-10.0-I-OUTD-CAN-208-NG	PVI-10.0-I-OUTD-CAN-480-NG
	PVI-10.0-I-OUTD-CAN-600-NG	
With DC switch and DC fuses	PVI-10.0-I-OUTD-S1-US-208-NG	PVI-10.0-I-OUTD-S1-US-480-NG
	PVI-10.0-I-OUTD-S1-CAN-208-NG	PVI-10.0-I-OUTD-S1-CAN-480-NG
	PVI-10.0-I-OUTD-S1-CAN-600-NG	
With AC and DC switches and DC fuses	PVI-10.0-I-OUTD-S2-US-208-NG	PVI-10.0-I-OUTD-S2-US-480-NG
	PVI-10.0-I-OUTD-S2-CAN-208-NG	PVI-10.0-I-OUTD-S2-CAN-480-NG
	PVI-10.0-I-OUTD-S2-CAN-600-NG	

Information in this document is subject to change without notice

Support and service

ABB supports its customers with a dedicated, global service organization in more than 60 countries, with strong regional and national technical partner networks providing a complete range of life cycle services.

For more information please contact your local ABB representative or visit:

www.abb.com/solarinverters

www.abb.com

© Copyright 2015 ABB. All rights reserved. Specifications subject to change without notice.

