

# SUN2000-29.9KTL Smart String Inverter



## Smart

8 strings intelligent monitoring



## Efficient

Max. efficiency 98.6%



## Safe

Fuse free design



## Reliable

Type II surge arresters for DC & AC

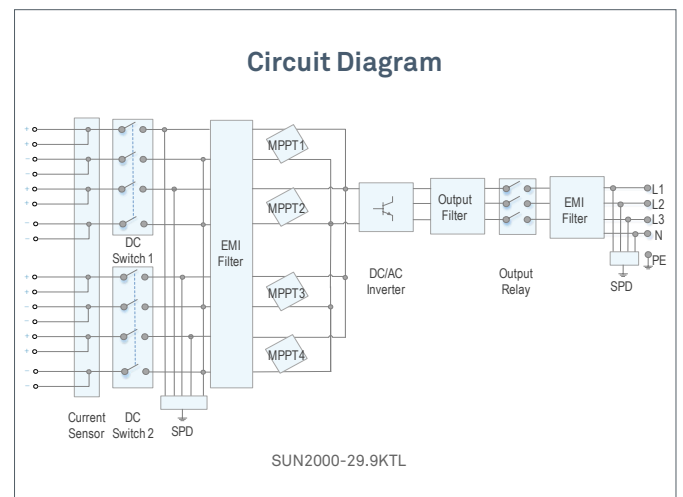
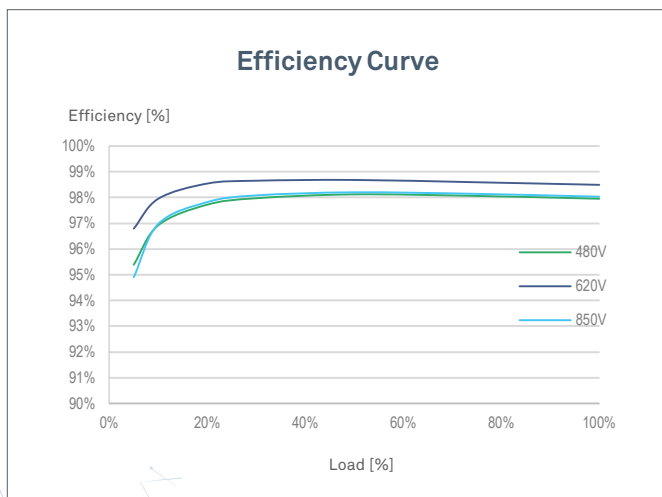

Technical Specification	SUN2000-29.9KTL
<b>Efficiency</b>	
Max. Efficiency	98.6%
European Efficiency	98.4%
<b>Input</b>	
Max. Input Voltage	1,100 V
Max. Current per MPPT	22 A
Max. Short Circuit Current per MPPT	30 A
Start Voltage	250 V
MPPT Operating Voltage Range	200 V ~ 1,000 V
Rated Input Voltage	620 V
Number of Inputs	8
Number of MPP Trackers	4
<b>Output</b>	
Rated AC Active Power	29,900 W
Max. AC Apparent Power	29,900 VA
Max. AC Active Power (cosφ=1)	29,900 W
Rated Output Voltage	400 V, 3W + N + PE
Rated AC Grid Frequency	50 Hz / 60 Hz
Rated Output Current	43.2 A
Max. Output Current	43.2 A
Adjustable Power Factor Range	0.8 LG ... 0.8 LD
Max. Total Harmonic Distortion	< 3%
<b>Protection</b>	
Input-side Disconnection Device	Yes
Anti-islanding Protection	Yes
AC Overcurrent Protection	Yes
DC Reverse-polarity Protection	Yes
PV-array String Fault Monitoring	Yes
DC Surge Arrester	Type II
AC Surge Arrester	Type II
DC Insulation Resistance Detection	Yes
Residual Current Monitoring Unit	Yes
<b>Communication</b>	
Display	LED Indicators, Bluetooth + APP
RS485	Yes
USB	Yes
Monitoring BUS (MBUS)	Yes
<b>General</b>	
Dimensions (W x H x D)	930 x 550 x 283 mm (36.6 x 21.7 x 11.1 inch)
Weight (with mounting plate)	62 kg (136.7 lb.)
Operating Temperature Range	-25°C ~ 60°C (-13°F ~ 140°F)
Cooling Method	Natural Convection
Max. Operating Altitude	4,000 m (13,123 ft.)
Relative Humidity	0 ~ 100%
DC Connector	Amphenol Helios H4
AC Connector	Cable Gland + OT Terminal
Protection Degree	IP65
Topology	Transformerless
<b>Standard Compliance (more available upon request)</b>	
Certificate	EN 62109-1/-2, IEC 62109-1/-2, EN 50530, IEC 62116, IEC 60068, IEC 61683
Grid Code	IEC 61727, AS/NZS 4777.2