



IQ7 Series Microinverters

The high-powered smart grid ready Enphase IQ7 Series Microinverters - IQ7+, and IQ7A dramatically simplify the installation process while achieving the highest system performance.



Enphase IQ Gateway
Part of the Enphase Energy System, IQ7 Series Microinverters integrate with the IQ Battery, IQ Gateway, and the Enphase App monitoring and analysis software.

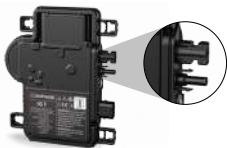

IQ7 Series with Integrated MC4 connectors
Connect PV modules quickly and easily to the IQ7 Series Microinverters that has integrated MC4 connectors.



IQ7 Series Microinverters redefine reliability standards with more than 1 million cumulative hours of power-on testing, enabling an industry-leading limited warranty of up to 10 years.*



Q-Relay 1P and 3P
Production and storage, circuit integrated, NS-protection device with PLC-Phase coupler (3P) and DC current injection monitoring.*



IQ Cables
The IQ Cables allow quick and safe connection of the microinverters. With 3P variants, the installed capacity is automatically distributed evenly across all three phases.

Easy to install

- Lightweight and compact with plug-n-play connectors
- Power Line Communication (PLC) between components
- Familiar AC cabling architecture

High productivity and reliability

- More than 1 million cumulative hours of testing
- Class II double-insulated enclosure
- Safer AC cabling methods

Smart Grid Ready

- Complies with the latest advanced grid support
- Remote automatic updates for the latest grid requirements
- Configurable to support a wide range of grid profiles

* IQ Relay is not required in all countries, check local grid connection requirements to confirm.

** 10-year warranty is valid provided an internet connected IQ Gateway is installed.

IQ7 Series Microinverters

INPUT DATA (DC)		UNITS	IQ7PLUS-72-M-INT	IQ7A-72-M-INT
Typical Module compatibility			60-cell / 120 half-cell, 66-cell / 132 half-cell, 72-cell / 144 half-cell	60-cell / 120 half-cell, 66-cell / 132 half-cell, 72-cell / 144 half-cell
No enforced DC / AC ratio and maximum input power. Modules can be paired as long as the Maximum input voltage is not exceeded and Maximum input current of the inverter at the lowest and highest temperatures are respected. See the compatibility calculator at https://enphase.com/installers/microinverters/calculator .				
Minimum / Maximum input voltage	U_{dcmin} / U_{dcmax}	V	16 / 60	18 / 58
Start-up input voltage	$U_{dcstart}$	V	22	33
Rated input voltage	$U_{dc,r}$	V	36	40.5
Minimum / Maximum MPP voltage	U_{mppmin} / U_{mppmax}	V	27 / 45	38 / 43
Minimum / Maximum operating voltage	U_{opmin} / U_{opmax}	V	16 / 60	18 / 58
Maximum input current	I_{dcmax}	A	12	10.2
Maximum module I_{sc}	I_{scmax}	A		20
Maximum short-circuit DC input current	I_{scmax}	A		25
Maximum input power	P_{dcmax}	W	440	500
OUTPUT DATA (AC)		UNITS	IQ7PLUS-72-M-INT	IQ7A-72-M-INT
Maximum apparent power	$S_{ac,max}$	VA	295	366
Rated power	$P_{ac,r}$	W	290	366
Nominal grid voltage	U_{acnom}	V	230	
Minimum / Maximum grid voltage	U_{acmin} / U_{acmax}	V	184 / 276	
Maximum output current	I_{acmax}	A	1.28	1.59
Nominal frequency	f_{nom}	Hz	50	
Minimum / Maximum frequency	f_{min} / f_{max}	Hz	45 / 55	
Maximum units per single / multi-phase 20 A circuit			13 (L+N) / 39 (3L+N)	11 (L+N) / 33 (3L+N)
Maximum units per single / multi-phase IQ Cable section			13 (L+N) / 21 (3L+N)	11 (L+N) / 18 (3L+N)
Centre feeding is best practice. These design limits should ensure voltage rise and line conductor resistance on the IQ Cable are maintained within acceptable limits.				
Protective class (all ports)			II	
Total harmonic distortion		%	<5	
Power factor setting			1.0	
Power factor range	$\cos\phi$		0.8 leading – 0.8 lagging	
Inverter maximum efficiency	η_{max}	%	97.24	97.23
European weighted efficiency	η_{EU}	%	96.50	
Inverter topology			Isolated (HF Transformer)	
Night-time power loss		mW	50	
MECHANICAL DATA			IQ7PLUS-72-M-INT	IQ7A-72-M-INT
Ambient air temperature range			-40°C to +65°C (-40°F to +149°F)	-40°C to +60°C (-40°F to +140°F)
Relative humidity range			4 % to 100 % (condensing)	
Overvoltage class AC port			III	
Number of input DC connectors (pairs) per single MPP-tracker			1	
AC Connector type			Enphase IQ Cabling (refer to separate datasheet for cable and accessories)	
DC Connector type			Staubli made MC4	
Dimensions (H x W x D)			212 mm (8.3") x 175 mm (6.9") x 30.2 mm (1.2") (without mounting brackets)	
Weight (with mounting plate)			1.1 kg (2.4 lbs)	
Cooling			Natural convection – no fans	

MECHANICAL DATA	IQ7PLUS-72-M-INT	IQ7A-72-M-INT
Enclosure	Class II double-insulated, corrosion resistant polymeric enclosure	
IP Rating	Outdoor - IP67	
Maximum altitude	< 2,600 metres	
Calorific value	37.5 MJ / unit	
STANDARDS	IQ7PLUS-72-M-INT	IQ7A-72-M-INT
Grid compliance (with IQ Relay)	AS / NZS4777.2:2020 + A1	
Safety	EN IEC 62109-1, EN IEC 62109-2	
EMC	EN IEC 61000-3-2, 61000-3-3, 61000-6-2, 61000-6-3, EN IEC 50065-1, 50065-2-1	
Product labelling	CE and RCM	
Advanced Grid Functions ¹	Power export limiting (PEL), Phase imbalance management (PIM), Loss of phase detection (LOP), Power factor control Q (U), cos (phi) (P)	
Microinverter Communication	Powerline communication (PLC) 110 – 120 kHz (Class B), Narrow band 200 Hz	

(1) Some of these functions require IQ Gateway Metered with current transformers and/or IQ Relay installed.

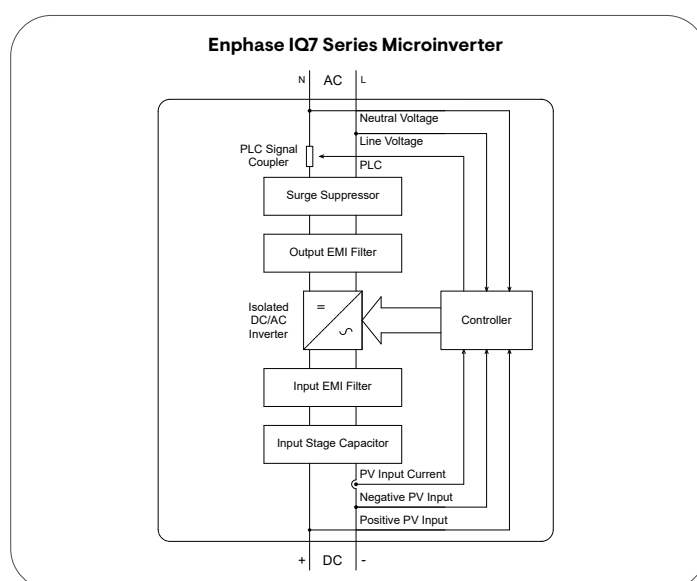
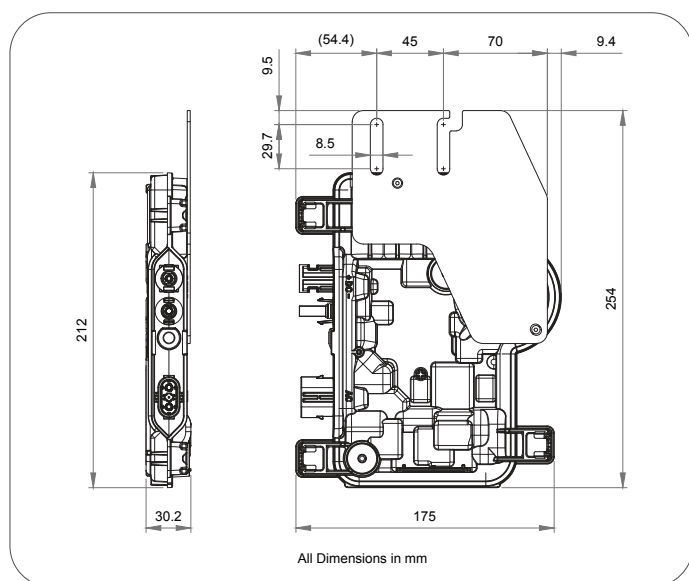
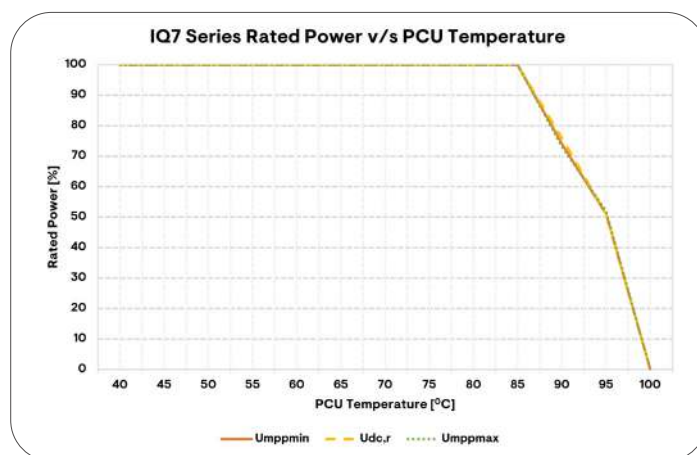
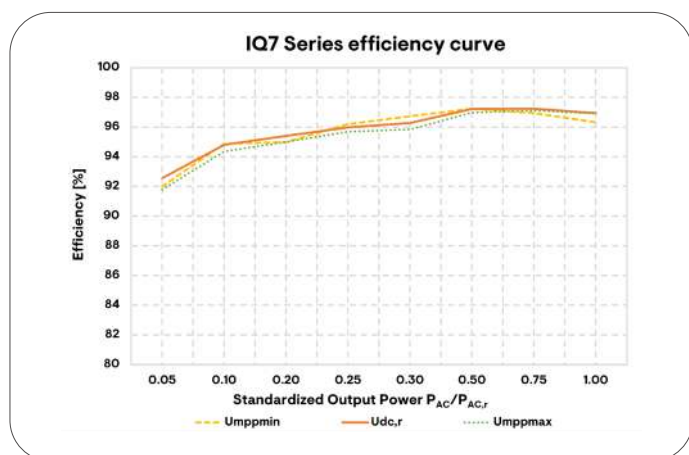

Assembled in China, India, and Mexico.

Enphase Energy, Inc. 47281 Bayside Pkwy, Fremont, CA 94538, United States

IQ7-DS-V1-MC4-EN-AU-2022-12-19