

# Harvest the Sunshine

## DEEP BLUE 3.0 Light

Mono

390W MBB  
Half-cell Black Module  
JAM54S31 380-405/MR/1500V Series

### Introduction

Assembled with 11BB PERC cells, the half-cell configuration of the modules offers the advantages of higher power output, better temperature-dependent performance, reduced shading effect on the energy generation, lower risk of hot spot, as well as enhanced tolerance for mechanical loading.



Higher output power



Lower LCOE



Less shading and lower resistive loss



Better mechanical loading tolerance

### Superior Warranty

- 15-year product warranty\*
- 25-year linear power output warranty

0.55% Annual Degradation  
Over 25 years

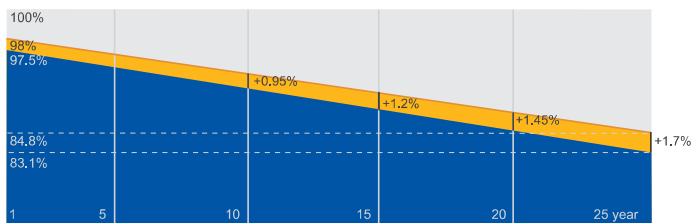

■ New linear power warranty ■ Standard module linear power warranty

### Comprehensive Certificates

- IEC 61215, IEC 61730
- ISO 9001: 2015 Quality management systems
- ISO 14001: 2015 Environmental management systems
- ISO 45001: 2018 Occupational health and safety management systems



# JA SOLAR

[www.jasolar.com](http://www.jasolar.com)

Specifications subject to technical changes and tests.  
JA Solar reserves the right of final interpretation.  
Shanghai JA Solar Technology Co., Ltd.



**MECHANICAL DIAGRAMS**

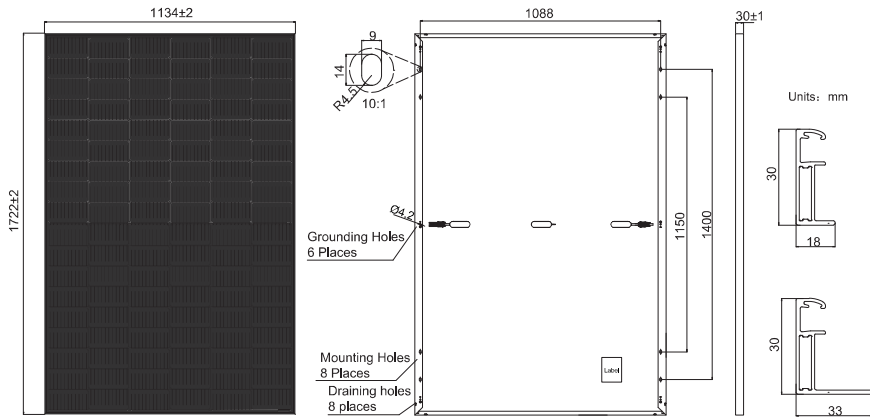

Remark: customized frame color and cable length available upon request

**SPECIFICATIONS**

Cell	Mono
Weight	21.5kg±3%
Dimensions	1722±2mm×1134±2mm×30±1mm
Cable Cross Section Size	4mm <sup>2</sup> (IEC) , 12 AWG(UL)
No. of cells	108(6x18)
Junction Box	IP68, 3 diodes
Connector	Stäubli MC4-EVO2 QC Solar QC 4.10-35
Cable Length (Including Connector)	Portrait: 300mm(+)/400mm(-); Landscape: 1200mm(+)/1200mm(-)
Country of Manufacturer	China/Vietnam

**ELECTRICAL PARAMETERS AT STC**

TYPE	JAM54S31 -380/MR/1500V	JAM54S31 -385/MR/1500V	JAM54S31 -390/MR/1500V	JAM54S31 -395/MR/1500V	JAM54S31 -400/MR/1500V	JAM54S31 -405/MR/1500V
Rated Maximum Power(Pmax) [W]	380	385	390	395	400	405
Open Circuit Voltage(Voc) [V]	36.58	36.71	36.85	36.98	37.07	37.23
Maximum Power Voltage(Vmp) [V]	30.28	30.46	30.64	30.84	31.01	31.21
Short Circuit Current(Isc) [A]	13.44	13.52	13.61	13.70	13.79	13.87
Maximum Power Current(Imp) [A]	12.55	12.64	12.73	12.81	12.90	12.98
Module Efficiency [%]	19.5	19.7	20.0	20.2	20.5	20.7
Power Tolerance	0~+5W					
Temperature Coefficient of Isc(α <sub>Isc</sub> )	+0.045%/°C					
Temperature Coefficient of Voc(β <sub>Voc</sub> )	-0.275%/°C					
Temperature Coefficient of Pmax(γ <sub>Pmp</sub> )	-0.350%/°C					
STC	Irradiance 1000W/m <sup>2</sup> , cell temperature 25°C, AM1.5G					

Remark: Electrical data in this catalog do not refer to a single module and they are not part of the offer. They only serve for comparison among different module types. Measurement tolerance at STC: Pmax ±3%, Voc ±3% and Isc ±4%.

**ELECTRICAL PARAMETERS AT NOCT**

TYPE	JAM54S31 -380/MR/1500V	JAM54S31 -385/MR/1500V	JAM54S31 -390/MR/1500V	JAM54S31 -395/MR/1500V	JAM54S31 -400/MR/1500V	JAM54S31 -405/MR/1500V
Rated Max Power(Pmax) [W]	286	290	294	298	302	306
Open Circuit Voltage(Voc) [V]	34.36	34.49	34.62	34.75	34.88	35.12
Max Power Voltage(Vmp) [V]	28.51	28.68	28.87	29.08	29.26	29.47
Short Circuit Current(Isc) [A]	10.75	10.82	10.89	10.96	11.03	11.10
Max Power Current(Imp) [A]	10.03	10.11	10.18	10.25	10.32	10.38
NOCT	Irradiance 800W/m <sup>2</sup> , ambient temperature 20°C, wind speed 1m/s, AM1.5G					

**OPERATING CONDITIONS**

Maximum System Voltage	1500V DC(IEC)
Operating Temperature	-40°C~+85°C
Maximum Series Fuse Rating	25A
Maximum Static Load, Front*	3600Pa, 1.5
Maximum Static Load, Back*	1600Pa, 1.5
NOCT	45±2°C
Safety Class	Class II
Fire Safety Class	Class C

**CHARACTERISTICS**

Current-Voltage Curve JAM54S31-405/MR/1500V

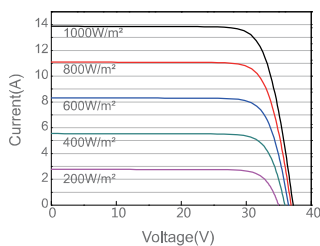

Power-Voltage Curve JAM54S31-405/MR/1500V

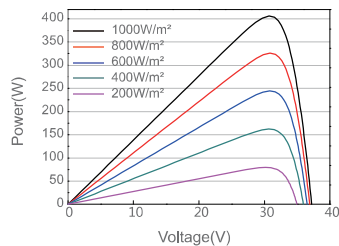

Current-Voltage Curve JAM54S31-405/MR/1500V

