

# SunPower Performance 7

SPR-P7-XXX-BLK

## Home Solar Panel

435-460 W | Up to 22.7% Efficient



Ideal for residential applications



Framed, glass-glass

### Enhanced Power Density

With high efficiency TOPCon cell technology offering strong LETID/LID-resistance, a lower temperature coefficient, and front-side conductive wires that support increased current collection, SunPower Performance panels are uniquely engineered to deliver more lifetime energy over standard solar panels.

### Proven Reliability

SunPower Performance panel durability is maximized in all types of weather conditions from an innovative shingled-cell design that features flexible interconnects that withstand the stresses of daily temperature swings, an advanced encapsulant that shields components from humidity-induced corrosion, one-third-cut cells that are partitioned through ‘non-destructive cutting’ that reduces the risk of cell micro-cracks, and an advanced electrical architecture that offers resilience against the effects of shade, while mitigating hot-spot formation.



### Comprehensive Warranty Coverage

Each SunPower Performance panel is manufactured with the absolute confidence to deliver more energy and greater reliability over time—and backed by one of the industry’s most comprehensive warranties.

Product and power coverage	30 / 30 Years
Year 1 minimum warranted output	99.0%
Maximum annual degradation	0.4%



## Performance 7 POWER: 435–460 W | EFFICIENCY: Up to 22.7%

Electrical Data, Front STC Characteristics <sup>1</sup>						
	SPR-P7-460-BLK	SPR-P7-455-BLK	SPR-P7-450-BLK	SPR-P7-445-BLK	SPR-P7-440-BLK	SPR-P7-435-BLK
Nominal Power (P <sub>nom</sub> ) <sup>1</sup>	460 W	455 W	450 W	445 W	440 W	435 W
Power Tolerance	+3/0%	+3/0%	+3/0%	+3/0%	+3/0%	+3/0%
Panel Efficiency	22.7%	22.4%	22.2%	21.9%	21.7%	21.4%
Rated Voltage (V <sub>mpp</sub> )	35.95 V	35.70 V	35.45 V	35.20 V	34.95 V	34.70 V
Rated Current (I <sub>mp</sub> )	12.80 A	12.75 A	12.70 A	12.65 A	12.60 A	12.54 A
Open-Circuit Voltage (V <sub>oc</sub> ) (+/-3%)	42.31 V	42.13 V	41.95 V	41.77 V	41.59 V	41.41 V
Short-Circuit Current (I <sub>sc</sub> ) (+/-4%)	13.52 A	13.45 A	13.38 A	13.32 A	13.29 A	13.27 A

Bifacial Gain <sup>2</sup>						
P <sub>max</sub> with 5% Bifacial Gain	483 W	478 W	473 W	467 W	462 W	457 W
I <sub>sc</sub> with 5% Bifacial Gain	14.20 A	14.12 A	14.05 A	13.99 A	13.95 A	13.93 A
P <sub>max</sub> with 10% Bifacial Gain	506 W	501 W	495 W	490 W	484 W	479 W
I <sub>sc</sub> with 10% Bifacial Gain	14.87 A	14.80 A	14.72 A	14.65 A	14.62 A	14.60 A
P <sub>max</sub> with 20% Bifacial Gain	552 W	546 W	540 W	534 W	528 W	522 W
I <sub>sc</sub> with 20% Bifacial Gain	16.22 A	16.14 A	16.06 A	15.98 A	15.95 A	15.92 A

Electrical Data	
Bifaciality (φP <sub>max</sub> )	80% +/-10%
Maximum System Voltage	1000 V IEC
Temperature	-40°C to +85°C
Maximum Series Fuse	25 A
Power Temp. Coef.	-0.29% / °C
Voltage Temp. Coef.	-0.25% / °C
Current Temp. Coef.	0.045% / °C

Packaging Configuration	
Number of modules per pallet	36
Number of pallets per 40ft HQ container	24
Number of modules per container	864

Tests And Certifications	
Standard Tests	IEC 61215, IEC 61730
Fire Rating	Class C (IEC 61730)
Quality Certs	ISO 9001:2015, ISO 14001:2015
EHS Compliance	ISO 45001-2018, Recycling Scheme
Ammonia Test	IEC 62716
Dust and Sand	IEC 60068-2-68
Salt Spray Test	IEC 61701 (Severity 8)
LeTID Test	TUV 2fg 2689/04.19 (LeTID Detection)
PID Test	IEC 62804

Mechanical Data	
Solar Cells	N-type Topcon
Glass	2.0 mm + 2.0 mm, high transmission heat strengthened glass, AR coating on front glass
Junction Box	IP-68, 3 bypass diodes
Connector	Stäubli MC4
Weight	24.8 kg
Max. Load <sup>3</sup>	Wind: 2400 Pa, 244 kg/m <sup>2</sup> front & back Snow: 5400 Pa, 550kg/m <sup>2</sup> front
Impact Resistance	40 mm diameter hail at 27.5 m/s
Frame	Black anodized aluminum alloy

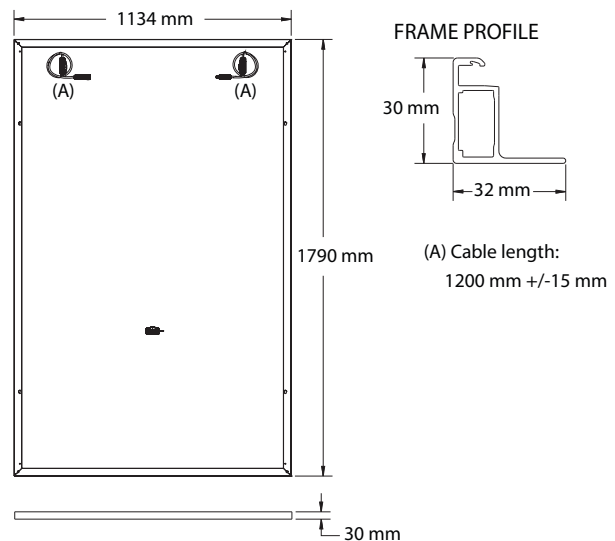

Please read the safety and installation instructions.  
Visit [www.sunpower.maxeon.com/int/PVInstallGuideIEC](http://www.sunpower.maxeon.com/int/PVInstallGuideIEC).  
Paper version can be requested through  
[techsupport.ROW@maxeon.com](mailto:techsupport.ROW@maxeon.com).



1 Standard Test Conditions (1000 W/m<sup>2</sup> irradiance, AM 1.5, 25° C). NREL calibration Standard: SOMS current, LACCS FF and Voltage.

2 As per IEC 61215-2016 tested and certified. See Safety and Installation Guideline for details.

3 As per IEC 61215-2016 tested and certified. See Safety and Installation Guideline for details.

Designed in U.S.A.

Assembled in China

Specifications included in this datasheet are subject to change without notice.

©2024 Maxeon Solar Technologies. All Rights Reserved.

View warranty, patent and trademark information at [maxeon.com/legal](http://maxeon.com/legal).

# SUNPOWER

FROM MAXEON SOLAR TECHNOLOGIES

552404 REV A / A4\_EN  
Publication Date: March 2024