

SunPower Performance 7

Commercial Solar Panel

530–550 W | SPR-P7-XXX-COM-S



Bifacial energy generation



Framed glass-glass



One-third cut, shingled-cell design

Reduced Operating Costs

The Performance panel delivers energy production your bottom line can count on—leveraging high efficiency cells and an advanced electrical architecture to generate the energy you need to hedge future power bills.

Secure, Reliable Investment

The advanced engineering of the Performance panel provides reliable high power and a longer product lifecycle to maximise your return-on-investment. Rest assured knowing our nearly 40-years of solar experience and best-in-class warranty prove these panels are up to the challenge, day-in and day-out.

A Better Product for a Better Planet

Recognised by third-party organisations as a sustainability leader, feel confident knowing your panel is produced from a clean supply chain with the highest quality standards of materials and human rights. It's a quick win for your ESG goals.

Corporate  Knights



A better product, a better warranty

SunPower Performance 7 panels are covered by a 30-year warranty. Manufactured for long-term durability — covering defects related to workmanship and materials for a full 30 years.

Product and power coverage	30 / 30 Years
Year 1 minimum warranted output	99.0%
Maximum annual degradation	0.4%



Performance 7 POWER: 530–550 W | EFFICIENCY: Up to 22.5%

Electrical Data, Front STC Characteristics ¹					
	SPR-P7-550-COM-S	SPR-P7-545-COM-S	SPR-P7-540-COM-S	SPR-P7-535-COM-S	SPR-P7-530-COM-S
Nominal Power (P _{nom})	550 W	545 W	540 W	535 W	530 W
Power Tolerance	+3/0%	+3/0%	+3/0%	+3/0%	+3/0%
Panel Efficiency	22.5%	22.3%	22.1%	21.9%	21.7%
Rated Voltage (V _{mpp})	43.08 V	42.85 V	42.63 V	42.40 V	42.17 V
Rated Current (I _{mpp})	12.77 A	12.72 A	12.67 A	12.62 A	12.57 A
Open-Circuit Voltage (V _{oc}) (+/-3%)	50.70 V	50.52 V	50.34 V	50.14 V	49.94 V
Short-Circuit Current (I _{sc}) (+/-4%)	13.48 A	13.45 A	13.42 A	13.39 A	13.36 A

Bifacial Gain ²					
P _{max} with 5% Bifacial Gain	578 W	572 W	567 W	562 W	557 W
I _{sc} with 5% Bifacial Gain	14.15 A	14.12 A	14.09 A	14.06 A	14.03 A
P _{max} with 10% Bifacial Gain	605 W	600 W	594 W	589 W	583 W
I _{sc} with 10% Bifacial Gain	14.83 A	14.80 A	14.76 A	14.73 A	14.70 A
P _{max} with 20% Bifacial Gain	660 W	654 W	648 W	642 W	636 W
I _{sc} with 20% Bifacial Gain	16.18 A	16.14 A	16.10 A	16.07 A	16.03 A

Electrical Data	
Bifaciality (φP _{max})	80% +/-10%
Maximum System Voltage	1500 V IEC
Temperature	-40°C to +85°C
Maximum Series Fuse	25 A
Power Temp. Coef.	-0.29% / °C
Voltage Temp. Coef.	-0.25% / °C
Current Temp. Coef.	0.045% / °C

Packaging Configuration	
Number of modules per pallet	33
Number of pallets per 40ft HQ container	20
Number of modules per container	660

Tests And Certifications	
Standard Tests	IEC 61215, IEC 61730 Rated to 1500 V
Fire Ratings ⁴	Spread of Flame: Class A Burning Brand: Class C
Quality Certs	ISO 9001:2015, ISO 14001:2015
EHS Compliance	ISO 45001-2018, Recycling Scheme
Ammonia Test	IEC 62716
Dust and Sand	IEC 60068-2-68
Salt Spray Test	IEC 61701 (maximum severity)
LeTID Test	TUV 2fg 2689/04.19 (LeTID Detection)
PID Test	IEC 62804



Mechanical Data	
Solar Cells	N-type TOPCon
Glass	2.0 mm + 2.0 mm, high transmission heat strengthened glass, AR coating on front glass
Junction Box	IP-68, 3 bypass diodes
Connector	Stäubli Evo2
Weight	30.3 kg
Max. Load ³	Wind: 2400 Pa, 245 kg/m ² front & back Snow: 5400 Pa, 550 kg/m ² front
Impact Resistance	40 mm diameter hail at 27.5 m/s
Frame	Silver anodized aluminum alloy

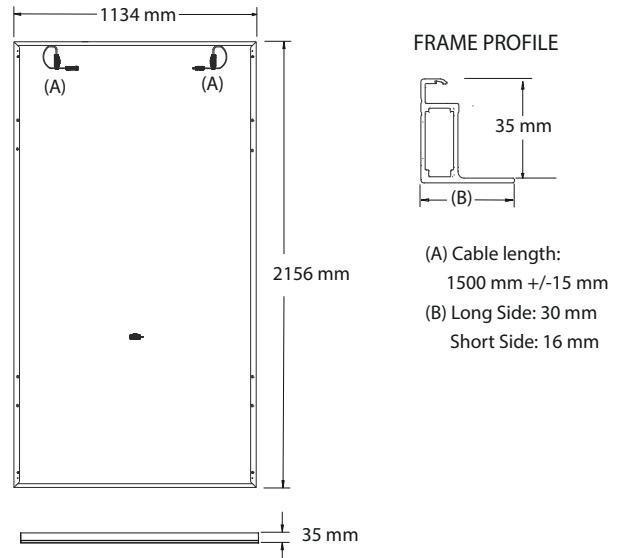

Please read the safety and installation instructions.
Visit www.sunpower.maxeon.com/int/PVInstallGuideIEC.
Paper version can be requested through techsupport.ROW@maxeon.com.

1 Standard Test Conditions (1000 W/m² irradiance, AM 1.5, 25° C). NREL calibration Standard: SOMS current, LACCS FF and Voltage.
2 The additional gain from the back side of the panel compared to the power of the front side of the panel at the standard test conditions. It depends on mounting (structure, height, tilt angle etc.) and albedo of the underlying surface.
3 As per IEC 61215-2016 tested and certified. See Safety and Installation Guideline for details.
4 As per IEC 61730-2 / UL 790.

Designed in U.S.A.
Assembled in China
Specifications included in this datasheet are subject to change without notice.
©2024 Maxeon Solar Technologies. All Rights Reserved.
View warranty, patent and trademark information at maxeon.com/legal.

SUNPOWER
FROM MAXEON SOLAR TECHNOLOGIES